

ARCBRO®

F1621

Portable Plasma Torch Height Controller Manual - F1621



Operator Manual

ARCBRO | Revision 2 | English

Date of issue: August, 2018

Unique Solution

WWW.ARCBRO.COM

Work condition

- ◆ Working Temperature, 0°C~50°C. Relative Humidity, 5~95%.
- ◆ Operation Voltage: 24VDC. MAX range: 21.6VDC-26.4VDC.
- ◆ The THC should be installed in a cab which can provide protection from powder.
- ◆ The THC should be better used in the situation without high electromagnetic radiation.

Maintenance

- This controller should only be operated by trained service person.
- Do not open the controller unless obtaining the authorization.
- Do not let any acid or alkalescency substance to corrode the controller and the divide board.
- Please turn off power supply if the controller does not need to work.

Safety notice

- ◆ This THC will switch in high electromagnetic, It can hurt me if we get to touch with high electromagnetic . Do not touch shield cable and wire when power supply is turning on.
- ◆ Packing pieces must be installed in accordance with the provisions and requirements of step.
- ◆ GND must follow THC instruction.

Installation note

THC first check on electrical safety : Before THC first power, Making all port of wiring connected, then unplug motor cable, in other words, do not connect lifting motor cable temporarily. Then powering on. **(Warning: Motor cable must be unplug before powering on, otherwise, the reason why the lift motor has been rising (declining) is that may be received collision signal, It can injury lifting motor)**

Check whether the collision function is normal: After THC power on, check whether the collision detection function is normal, by observing the collision indicator light to determine whether the normal. Of the following circumstances:

Service Support Spirit

1. If the collision indicator light is turning on, really need to check whether a collision, for example, whether proximity switch is divorce, whether torch retaining cap and steel is touching.

If we only use torch retaining cap to detect collisions, separated from the protective cap and cutting steel. Because there is no contact with torch retaining cap and steel, the meaning that the collision has not take place, the collision indicator light should be take off.

If we only use proximity switch to detect collisions, parameter P13 should be set to 1, the meaning that allow the use of proximity switch detects a collision signal. Under normal circumstances, the collision indicator light is turning on when proximity switch is divorce; the collision indicator light is breaking down when proximity switch is not divorce. If we use in scene, the collision indicator light is breaking down when proximity switch is divorce, or the collision indicator light is turning on when proximity switch is not divorce, it explain that the description of the received signal and the normal, L09 need to set the value of the inverse. After parameter is set correctly, proximity switch can accurately reflect the situation of collision.

If we use proximity switch and torch retaining cap to detect collisions at the same time, need to check respectively each set whether can accurately reflect the situation of collision. If a certain way is failing, please use their method by alone to troubleshoot and fix, until it can accurately reflect the situation of collision.

2. If the collision indicator light is breaking off, please make some collision conditions by man, check whether the collision indicator light can be turned on. For example, when we use torch retaining cap to detect collisions, if we make torch retaining cap and cutting steel short circuit by metal screwdriver, the collision indicator light should be turned on. Or when we use proximity switch, if we make torch connector crooked by hand, make proximity switch take off, the THC collision indicator light should be turned on. If make visible collision conditions by man and the collision indicator light cannot be turned on, we need to check whether the parameters can be set orderly.

Switching in lift motor safely: After the detection of THC collision has debug and used normally, please remove all conditions which can made collision, at the same time, THC collision indicator light should be broken off . Then turning off power source of THC and connecting the lift motor cable.

Check whether direction of lift move is true: After motor cable has been linked, power-on ,when check whether the button named 【▲】 in THC faceplate is pressed, observe whether the lift body is rising; when the button named 【▼】 is pressed, observe whether the lift body is declining. If the button named 【▲】 is pressed, the lift body is declining rather than

Service Support Spirit

rising, or if the button named 【▼】 is pressed, the lift body is rising rather than declining, it means that direction of motor rotation is not true. Please enabling the value of P12, or exchange two cable of lifting motor. It is best that ensure the button 【▲】 and 【▼】 in THC faceplate is consistent with direction of the lift body move.

Check arc start and used for IHS(initial height sensing): check whether start arc by pushing button of 【text arc start】 and check whether accomplish the initial positioning by pushing button of 【text used for IHS】 .

Putting in Arc voltage cable true: The wire of plasma arc voltage and cable of checking collision must be access to the corresponding port true, otherwise, it can lead to danger.

Demand that torch retaining cap used for IHS wiring: After the cable of plasma anode must be received a work piece, the action that detects the torch retaining cap collision and the initial positioning can work.

Using shielded cable wiring: In order to protect equipment work, please use shielded cable in our equipment. You can connect shielding layer in Shielded cable to THC side and use single point grounding.

Voltage divide board and voltage divide ratio: The ratio in THC is 100: 1. And effective measuring voltage in THC is 0~660V DC

Contents

Work condition	2
Maintenance	2
Safety notice	2
Installation note	2
Chapter 1 Overview	6
1.1 equipment presentation.....	6
1.2 Features of equipment	7
1.3 Function of equipment.....	8
1.4 Technique parameter	11
1.5 THC Installation size	12
Chapter 2 System operation	13
2.1 Operation panel button of explaining	13
2.2 operation panel of explaining	14
2.3 Menu operation explain	16
2.4 Motor drive current	25
2.5 Working process.....	25
Chapter3 Port connection	26
3.1 The case view	26
3.2 Chassis port	27
3.2.1 CNC port.....	27
3.2.2 Power supply, motor and motor limit port	29
3.2.3Arc start port and proximity switch position port.....	31
3.2.4 USB port	35
3.3 voltage divide port.....	37
3.3.1 arc voltage port	37
3.3.2 torch retaining cap detection circuit port	38
3.4The total wiring diagram	40
Chapter 4 common problems.....	41

Chapter 1 Overview

1.1 equipment presentation

Portable Plasma Torch Height Controller type F1621 is a product which has such advantage as operate simply, stabilize property, full function and high performance ratio. It is made on basis of condition that used in plasma power source scene, and it absorb a lot of advantage of THC all around the world.

This equipment uses the basic constant current characteristics of the plasma power supply, detects the change of the plasma cutting torch height by detecting the change of the plasma arc voltage, and controls the height between the cutting torch and the workpiece in real time.

It is suitable able for the height control of plasma power cutting torch with constant current characteristics or constant current characteristics within a certain voltage range. It is more suitable able for torch height control of portable cutting machine.

The device is light and portable, simple to operate, easy to use, and all buttons and knobs are humanized design, which is comfortable and convenient.



Figure 1.1 the (type F1621)

1.2 Features of equipment

- ↪ Our equipment uses nixie tube and LED as arc voltage and signal display, clear display, stabilization and anti-interference, long serve life.
- ↪ The parameter is able to alter by button and rotary knob in our equipment, easy to use.
- ↪ Our equipment uses the installed way which has 60 degree of slope, it suitable able to use portable cutting machine
- ↪ Our equipment has voltage divide and make all angle shield by metal, smaller volume, better anti-interference.
- ↪ It has simple and convenient parameter which can be set, change operation parameter flexibly, suitable able complex working conditions.
- ↪ It can suitable able external working conditions by changing parameter, so we need not change hardware within equipment.
- ↪ It can change the electrical level of input signal which is useful. The input signal acquiesce in low electrical level is useful. The high electrical level is useful when we change it.
- ↪ Input and output is insulated by optocoupler, it is useful to protect equipment from damage when voltage is bigger and electromagnetism pulse is disturbed.
- ↪ The arc start relay and the arc start prosperity relay is omron power relay, so it is reliable when it work.
- ↪ It can observe the electrical level in work process.
- ↪ The different work process is mutual seal, it can avoid operate fault.
- ↪ When THC has a delay of boring a hole, it can use function which it can dynamic bore a hole after arc start is start.
- ↪ It can monitor whether arc start has been start in torch process, if it detect that arc is breaking off, the THC can inform CNC in time and turn off the arc start relay, it can avoid to cite arc for empty when arc is breaking off.

Service Support Spirit

- ↳ When auto height control is proceeding, it can ensure that practical arc voltage follow setting arc voltage is closely, it hardly has error.
- ↳ When auto height control is proceeding, it also can change the arc voltage setting value, it is easy to change torch height slightly when torch is working.
- ↳ When auto height control is proceeding, collision signal can feedback for numerical control system, it can avoid that numerical control system is marching after collision.
- ↳ When auto height control is proceeding, it can use function which arc voltage can be adjusted by machine auto control
- ↳ After torch has accomplished, THC can automatic promote torch height, and height which we promote can setting casually.

1.3 Function of equipment

1. Auto initial height sensing(IHS)

The way of IHS has the detection way of proximity switch and the detection way of torch retaining cap collision.

- Proximity switch location detection

Our equipment uses NPN model proximity switch (or PNP model proximity switch), proximity switch is contacting when it do not work. When down testing or arc down initially, if torch collide workpiece(or if collide workpiece make torch tilt), proximity switch will break away from, then detection voltage can check this signal, it can promote the touch height which down initially(height can change by the panel spin button named "down height"). When proximity switch is breaking away from for long time, torch can keep straight rise until it collide upper limit of motor.

- Torch retaining cap collision detection

When we test collision by torch retaining cap, if torch retaining cap connect with work piece, detection voltage can be start and promote the touch height which down initially(height can change by the panel spin button named "down height"). After torch rise, torch retaining cap depart from work piece and collision signal reset at once. If torch retaining cap signal is keeping for long time, torch can keep straight rise until it collide upper limit of motor.

- Dual speed of IHS

Service Support Spirit

After down initially, torch can descend 6 second at fastest speed (the time can change by menu), then it descend at lowest speed (the lowest speed= the fastest/4) until torch collide work piece. Two kinds of speed down can promote work efficiency, descend in appropriate height, reduce collision impact, and extend serve life of torch retaining cap.

2. Auto arc voltage height control

When it fit to start auto height control, if arc voltage do not exceed 30V which we has been set up(parameter can change by menu), the THC will start auto height control.

3. Auto torch promote after collision

When collision happen in a condition which torch and down is not working, torch can automatic promote, the time named urgency collision rise spear time. When down initially detection is working, or when collision happen within torching, auto torch promote, the time named down height time.

4. Auto torch promote after torch is accomplished

After torch is accomplished, auto torch promote, height can change by setting parameter.

5. Manual operation

Many functions can be manual operated on operation panel of THC, such as, set auto/manual mode of THC, manually control torch up and down, IHS test arc start test.....etc.

6. Auto operate

After numerical control system send arc start signal, THC can automatic accomplish down initially—arc start—arc start feedback success, after CNC receive signal which arc start feedback is successful, machine tool start to motion and incise.

7. The function of displaying and monitoring

THC display arc voltage value by using two nixie tube, the green nixie tube above equipment is used for display arc voltage setting value, the red nixie tube under equipment is used for display actual value of arc voltage. It is convenience for user to monitor arc voltage value in incising.

8. Menu Operation

When torch is not working, parameters can be changed by panel button. Users can flexibly change speed, working way and so on.

9. Spin button operation

Service Support Spirit

The panel has three spin buttons; it can change arc voltage, initial height and delay time for piercing.

10. High and low level control

Input switch can choose using low level or high level, it can suitable able complicated applied environment. The default level is low. Also it can be changed by menu.

11. The function of avoiding collision

When torch is working, if the lower arc voltage setting value(or nozzle loss) lead to torch collide work piece, THC can send rise signal , it can avoid torch collide work piece continually and damage work piece. When collision happen in a condition which torch is working, if collide has happened several times, we can make numerical control stop work. Before equipment leave factory, if collision is happening, CNC will make torch stop work. If user do not make collision input signal connect with CNC, so when collision happen a condition which torch is working, CNC cannot receive the collision signal, it make torch continue to work. Whatever numerical control system whether has stopped torch, when collision happened, THC can promote torch height automatically until down height initially.

When torch is not working, if torch collide steel plate, torch will automatic promote a height named urgency collision rise spear height(in general, this height is higher than down height, and this parameter can be change).

12. Intelligent arc voltage adjust

When intelligent arc voltage adjust is been use and torch is working, if torch collide continuously steel plate twice, arc voltage can increase automatically a value which we has set (this parameter can be change, it is 5V that we set), for example, if arc voltage setting value is 110V, after torch collide continuously steel plate twice, arc voltage setting value increase automatically 5V, arc voltage setting value is 115V now, it can promote torch height to avoid collide work piece when torch is working.

13. Dynamic pierce function

During torch is working, if set-pierce has delay, torch can promote a height when arc start work at the moment. Before delay time of piercing has accomplished, torch can descend a height which it is the same with promoting height. It can be named dynamic pierce function similarly. When piercing is working, torch need promote a height, it can avoid dress get into torch head. If dynamic pierce lifting times that we set is 0, torch cannot promote when arc start is working.

Service Support Spirit

14. Collision signal feedback

THC can make numerical control system receive collision feedback signal, it can avoid that torch is working after collision has happened. THC make CNC receive collision feedback signal after collision happened several times, it can keep coherent torch.

1.4 Technique parameter

- * Work voltage: Rated DC 24V (The range is 21.6VDC-26.4VDC) .
- * Lifting motor: DC 24V.
- * Motor drive: PWM.
- * Output current: 0A-3A (the electric current that motor can input is 5A).
- * Load capacity: 100W.
- * Working temperature: 0°C~50°C .
- * IHS: proximity switch of IHS.
- * Torch retaining cap of IHS.
- * Voltage divide ratio: 100: 1
- * The precision of arc voltage sampling: 0.2V
- * The precision of arc voltage adjust: 1V
- * The speed of lifting: It determines by highest speed of lifting.
- * Setting range of arc voltage: 30V~600V, it can change by panel spin button.
- * The biggest torch following speed: It determines by highest speed of lifting.
- * Overload protect: auto overload、overheating、lack of voltage protect, making power source connect adversely to protect itself.

Service Support Spirit

1.5 THC Installation size

THC installation size: width 271mm, depth 190mm (it cannot contain line and port in back), height 70mm.

THC installation screw of IHS:

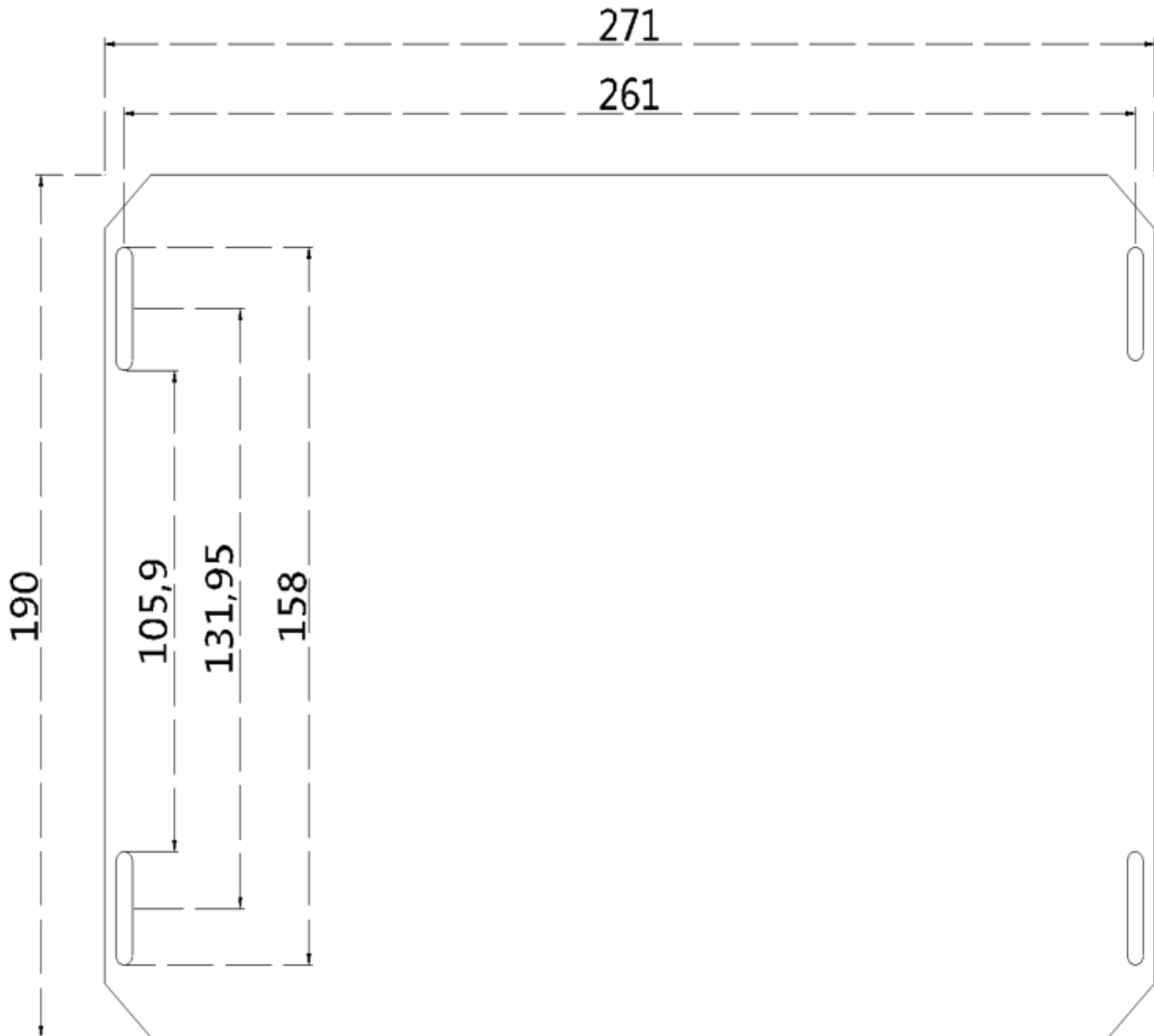

Chapter 2 System operation

2.1 Operation panel button of explaining

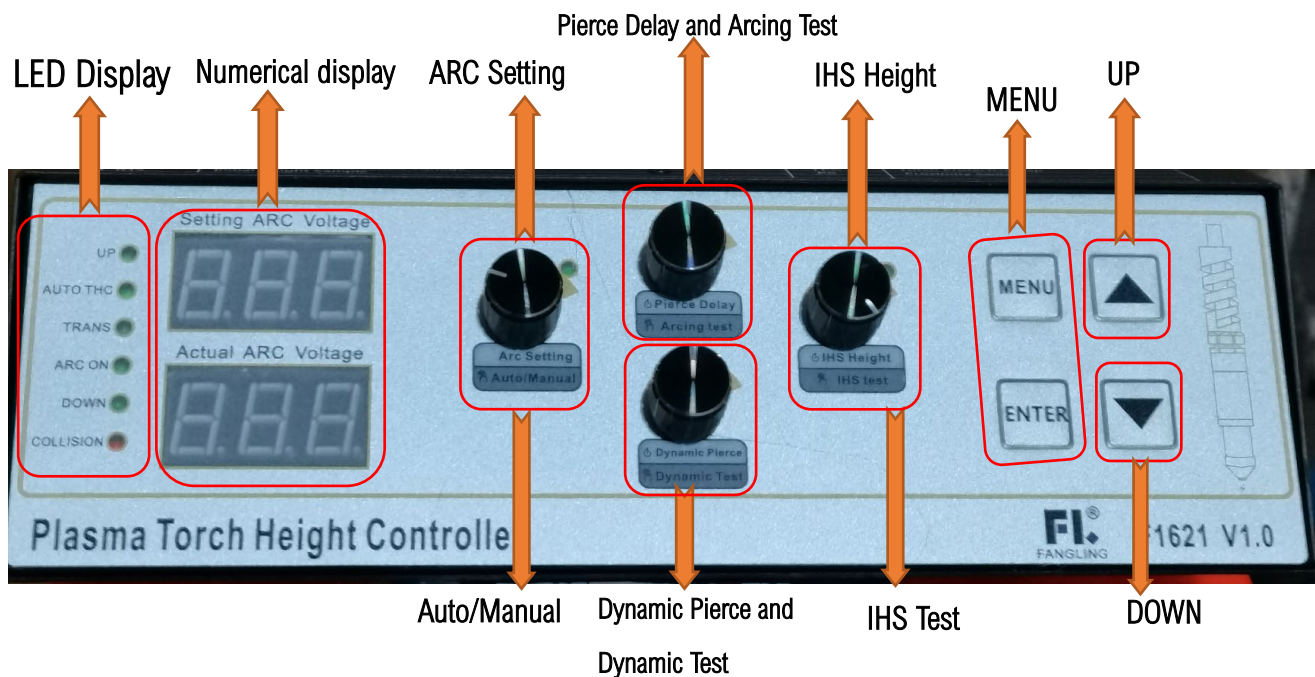

【▲】 : Torch up button. Rising is earlier than declining.

【▼】 : Torch down button.

【MENU】 : It is also named as 【MENU】 . Menu function button of choosing, and different condition has different function.

【OK】 : It is also named as 【OK】 . After entering into menu, if this button has been pressed at the first time, the parameters are able to be modified, After modified, the parameter will be confirmed when the button is pressed at the second time.

【+】 : when parameter is switching, the button can increase the parameter number progressively. When parameter is amending, the button can increase the parameter value.

【-】 : when parameter is switching, the button can decrease the parameter number progressively. When parameter is amending, the button can decrease the parameter value.

【AUTO】 : it is also named as 【AUTO】 , it is used for switching the condition which allow auto height control. Whenever the button has pressed, the light above the button can change condition. If the light is lighted, THC can start auto height control during torch is working. If the light is gone out, auto height control will stop work. The light is lighted when THC is start.

Service Support Spirit

【ARCON TEST】 : it is also named as **【ARCON TEST】** . During torch do not work and menu operation do not use, plasma can start arc(arc start relay is closed) when button has been pressed, and it can stop start arc(arc relay is opened) when button has been loosened. If arc start button of testing is loosened, torch will lift up an height which named torch accomplishment height of putting the spear.

【IHS TEST】 : it is also named as **【IHS TEST】** . IHS button of testing. During torch do not work and menu operation do not use, if the button is pressed first, THC will start IHS until down is accomplished. If the button is pressed again during down is working, or **【▲】** is pressed, down will stop work. The light above the button is lighted during IHS test. If IHS test finish, the light will go out.

2.2 operation panel of explaining

1.Displaying with Nixie tube: Arc voltage value is displayed by two nixie tubes in the front operation panel. During torch do not work and menu operation do not been used, it can display arc voltage 、 IHS 、 pierce delay value and so on. The green nixie tube is used to display arc voltage setting value; the red nixie tube is used for display actual value of arc voltage. Arc voltage setting value can be changed by turning the button named **【ARC SET】【(ARC SET)】** , and the value displayed with green nixie tube will be changed at the same time. The red nixie tube display 0 when plasma do not been working. The value displayed with red nixie tube is actual arc voltage value during plasma is working.

2.Parameter spin button of setting:

There has three spin button of spin encoding in panel.

The spin button named “ARC SET” : When menu operation do not use, arc voltage value can change by turning this spin button. If it turn clockwise, arc voltage value will increase. If it turn anticlockwise, arc voltage value will decrease. Arc voltage setting value is displayed in yellow nixie tube. When we change arc voltage setting value, it should on the basis of workpiece thickness and torch speed, it also need use parameter which offer by plasma power source. Torch height depend on Arc voltage value when torch is working.

During torch is working, arc voltage setting value also can change by spin button, and it can adjust torch height. This operation suitable able to adjust slightly torch height when torch is working.

Service Support Spirit

The spin button named “Piercing Delay” : When menu operation do not use, turning the button can change the value of piercing delay time. If it turn clockwise, the value of piercing delay time will increase. If it turn anticlockwise, the value of piercing delay time will decrease. When the spin button is turned, the yellow nixie tube display “Dly”, the red nixie tube display piercing delay time, the unit is second.

When THC use the piercing delay time which user set, it can send arc OK signal to CNC after piercing delay is finishing and arc voltage by sampling is effective. Some CNC has piercing delay time, but this delay is calculated when CNC receive arc OK signal. The authentic piercing delay time is the sum of piercing delay time of THC and piercing delay time of CNC. If user do not want to use the piercing delay time of THC, user can set it as zero.

The spin button named “IHS Height” : When menu operation do not use, turning the button can change height of IHS. If it turn clockwise, the height of IHS will increase. If it turn anticlockwise, the height of IHS will decrease. When the spin button is turned, the green nixie tube display “IHS”, the red nixie tube display the height of IHS. The height of IHS set by delay, the unit is second.

When menu operation do not use, two nixie tube is display arc voltage setting value. If user turn the spin button named “Piercing Delay ”or the spin button named “IHS Height”, it will display corresponding character. If the spin button is not turned for a long time, the nixie tube will display arc voltage setting value.

3. Working condition indicator:

The panel has 8 LED light:

UP indicator: This LED light is turned on when torch lift up.

AUTO THC indicator: This LED light will be turned on when the THC is working in auto height controlling processing. If it satisfy four conditions below, the indicator will turn on:

- A. The indicator named “AUTO” is turned on.
- B. CNC Auto height control enables.
- C. THC has sampled valid arc voltage.
- D. The sampling arc voltage do not exceed the value added between arc setting voltage and arc protecting voltage(in general, the value is 30V and can been changed).

Service Support Spirit

TRANS indicator: The indicator is lighted, it means system has detected the effective arc voltage value and piercing has completed. (it is piercing delay time of THC over, it is not contain the piercing delay time of CNC).

ARC ON indicator: Turn on when THC send arc start signal out. If IHS completed, this indicator is lighted when THC send arc start signal. During arc start test, the indicator is lighted.

DOWN indicator: Turn on when torch lift down.

COLLISION indicator: Turn on when torch touch workpiece or proximity switch effective.

AUTO indicator: The indicator up the button named **【AUTO】** is indicated whether allowed auto height control. If the indicator is lighted, THC will allow auto height control. If the indicator is extinguish, THC will not allow auto height control. The indicator is lighted after starting up. The indicator condition will change when the button named **【AUTO】** is pressed.

IHS TEST indicator: The indicator up the button named **【IHS TEST】** is lighted during IHS test, it means IHS test is working. The indicator is extinguish during other condition.

2.3 Menu operation explain

THC has concise menu, it can set some parameter and adopt to different work condition. Menu operation use the button named **【MENU】**、**【OK】**、**【+】**、**【-】** and so on. It also use two nixie tube to display parameter, the green nixie tube display parameter number and the red nixie tube display parameter value.

When user use it on the scene, parameter number and meaning can refer to concise parameter grid up the chassis.

During torch do not work, when arc start and IHS test do not work, user press the button named **【MENU】** can enter into the menu operation model. After it enter into the menu model, the button named **【IHS TEST】**、**【ARCON TEST】** is trashy. Only the button named **【▲】**、**【▼】** and the signal named THC_UP、THC_DN that CNC send is useful. If THC enter into the menu model, it will not test and cut.

When THC enter into the menu model, it mean THC enter into first submenu named “Pxx” (xx is parameter number), if the button named **【MENU】** is pressed again, THC will enter into second submenu named “Hxx”. When the button named **【MENU】** is pressed, THC can switch the next submenu. When it has switched the last submenu, if the button named **【MENU】**

Service Support Spirit

is pressed, it will exit the menu model. THC can test and cut until it exit the menu model. So user need exit the menu model in time after parameter has changed.

When THC switch submenu, the submenu is in a view model, it display first parameter of submenu. For example, the first parameter of first submenu is named “recover factory parameter”. The yellow LED display “P00”, the red LED display “ 1 ” .

When the submenu is in view model, pressing the button named **【+】** can switch the next parameter in same submenu. For example, the yellow LED display “P01” , when the button named **【+】** is pressed, it can display “P02” . The red LED display value of P02. When the button named **【+】** is pressed again, it can display “P02” , by parity of reasoning. Similarly, pressing the button named **【-】** can go back the last parameter successively.

When the submenu is in view model, pressing the button named **【OK】** can enter into the parameter modification model. Then the red LED start flicker, it means this parameter is waiting for changing. Pressing the button named **【+】** / **【-】** can increase/decrease parameter, the value which user change will display in the parameter. After parameter has changed, user can save it by pressing the button named **【OK】** and cancel it by pressing the button named **【MENU】** .

If user save it by pressing the **【OK】** button, the red LED will stop flicker and display the value which user has change. If the parameter has be changed and user cancel it by pressing the **【MENU】** button, the red led will stop flicker and display the value which the parameter is not changed.

THC has “Pxx” “Hxx” “Lxx” three submenu. With the addition of non-menu model, it has four condition. When the button named **【MENU】** is pressed, THC can switch in four condition circularly. Warning: During the non-menu model, if THC is testing or auto height control is working, THC will not enter into the menu model and change parameter. Similarly, if THC has entered into menu model, it will not start test and auto height control. After the parameter has changed, user must be remember to exit menu model in time.

“Pxx” submenu contain 21 parameters, they are “P00”~“P20” and contain sundry quantification parameter. The sundry parameter can change in this submenu.

“Hxx” submenu contain 9 parameters, they are “H01” ~ “H09” . It is used to check input signal is high level or low level. The sundry parameter can not change in this submenu. Warning: During torch start to work, pressing the button named **【MENU】** can look up the level condition of input port.

“Lxx” submenu contain 9 parameters, they are “L01”~“L09” . It can be set the input signal as high level effective or low level effective. The sundry parameter can change in this submenu.

Service Support Spirit

“Pxx” submenu listing:

PXX. NO.	Setting range	Step and length adjust	Initial Parameter	Yellow LED	Red LES	Remark
P00	0-1	1	1	P00	1	Recovering amending parameter interval
P01	0-50	1	50	P01	50	Setting manual lift speed of torch, the minimum speed is 0, the maximum speed is 50. CNC_THC_UP also use this speed.
P02	0-50	1	50	P02	50	Setting manual descend speed of torch , the minimum speed is 0, the maximum CNC_THC_DN also use this speed.
P03	0-50	1	50	P03	50	Setting auto lift speed, minimum is 0,maximum is 50.
P04	0-50	1	50	P04	50	Setting auto descend speed, minimum is 0,maximum is 50.
P05	10-50	1	30	P05	30	Unit: Volt(V). The value of protecting arc voltage. It can avoid torch descend rapidly because of arc voltage increase too big.
P06	1-10	1	1	P06	1	Unit: volt(V). The arc voltage precision of adjusting. For example, setting it as 1V, if D-value between setting arc voltage and practical arc voltage is under 1V, it will not start auto start.
P07	1-50	1	6	P07	6	Sensitivity coefficient can make the sensitivity higher. But if it is too higher, torch will quiver around the balance location.

Service Support Spirit

P08	0.1-9.99	0.01	2	P08	2.0	Unit: second(S). During torch do not work , the time is urgency rise spear time when torch collide the steel.
P09	3-20	1	5	P09	5	Unit: volt(V). The arc voltage value of auto adjust. During torch work, if torch collide the steel twice continuously, the arc voltage value of setting will increase this parameter automatically.
P10	0 or 1		0	P10	0	Enabling arc voltage auto adjust. When user set it as 1, it can allow arc voltage to adjust automatically.
P11	0-5	1	0	P11	0	During torch work, it allow that collision can happen several time then make THC stop to work. When user setting it as 0, if the collision happen is checked by send collision halt signal to CNC during torch work.
P12	0 or 1		1	P12	1	Switching motor contrary or positive direction changing parameter can change the motor direction of rotating.
P13	0 or 1		1	P13	1	Enable the proximity switch collision check. When user set it as 1, the proximity switch collision check is allowed.
P14	1-50	1	50	P14	50	Brake speed adjust step and length. When set it as 50, brake speed is fastest.
P15	1-100	1	100	P15	100	Speed adjust step and length when motor turn contrary. The bigger value can make reversal transition speed become more and more smaller.
P16	0.1-2	0.01	0.2	P16	0.2	Unit: Second(S). Arc voltage delay time of setting.

Service Support Spirit

P17	0-10	0.1	1	P17	1.0	Unit: Second(S). The lifting time of starting up.
P18	0.1-1	0.1	2	P18	2.0	Unit promoting the spear after torch has accomplished
P19	0-9.99	0.01	0	P19	0	Unit : Second(S).Torch when arc start to work.
P20	0-20	0.1	6	P20	6.0	Unit descending rapidly during the dual speed IHS.

Parameter explain particularly:

- ◆ P00: Recovering factory parameter. P00 can display 1. If user set it as 0 and save this parameter, all kinds of parameter in our equipment will recover factory parameter. After user exit the submenu, they can find that P00 display 1.
- ◆ P01, P02, P03, P04: Setting manual lifting and auto lifting speed of torch. The minimum speed is 0, the maximum speed is 50.
- ◆ P05: The value of promoting arc voltage. During torch is cutting, if gun of torch go through the crack of torch, arc voltage can rise immediately. If way of protecting arc voltage is not used, gun of touch will descend by fast speed. In serious condition, gun of torch and workpiece can collide by faster speed. After user set this parameter, when arc voltage exceed the value of setting, torch height will not change. It is useful to protect torch. In genal ,we set it as 30V.
- ◆ P06: The arc voltage precision of adjusting. For example, if user set the parameter as 1V, it means when D-value between setting arc voltage and practical arc voltage is under 1V, torch height will not be adjusted. If user set the parameter as 3V means when D-value between setting arc voltage and practical arc voltage is under 3V, torch height will not be adjusted.
- ◆ P07: Sensitivity coefficient. When arc voltage is changing, more and more bigger parameter can make torch adjust become more and more faster. But if parameter is too big, torch is easy to quiver around the balance location. If parameter is too small, torch can has slow follow speed. In genal, we set it as 6. When user use it, it can be adjust on the basis of torch effect.

Service Support Spirit

- ◆ P08: The time of torch rise spear urgently. During torch do not work , when torch collide the steel, THC can use fastest speed rise spear urgently in this time.
- ◆ P09, P10: Setting the function of arc voltage auto adjust. During torch is cutting, because of the arc voltage that user set is too low, or with service life of plasma pierce is decreasing, arc voltage in plasma power source can rise. If arc voltage value of setting is invariant, height will drop and it even can collide pierce after auto height control. During torch is cutting, when collision has happened, if user want to make torch promote some height and continue to cut, This function will be used by user. According to this function, THC can increase arc voltage value of setting automatically and increase torch height after collision happen twice. It can avoid torch continue collide pierce. During torch is cutting, when collision has happened, if user want to make torch promote some height and continue to cut, this function will be forbidden by user.
- ◆ P11: The time of allowing collision happen during torch work. During torch is cutting, if user allow torch continue to cut after collision has happened, user can set the time of allowing collision happen by changing this parameter. For example, user set the parameter as 1. Then during torch is cutting, when first collision happen, THC can not send collision signal to CNC. But THC can make torch promote a IHS height automatically. When collision happen again, THC can send collision signal to CNC. After CNC receive this signal, torch stop to work. In other example, user set the parameter as 3. After collision happen at the fourth time, THC send collision signal to CNC and the input is TO CNC COLLISION.
- ◆ P12: Switching motor contrary or plus direction of rotating. If user develope direction of motor and the button of lifting/descending is different, they enable this parameter will change direction of motor. For example, when user set P12 as 1, if the button of lifting is pressed, motor will descend. When user set P12 as 0, if the button of lifting is pressed, motor will lift.
- ◆ P13: Enable the proximity switch collision test. When user set it as 1, THC can use the proximity switch to test collision. When user set it as 0, THC can not use the proximity switch to test collision. When user set it as 1, user need make proximity switch put in THC and ensure that proximity switch is not breaking away from. Otherwise, lifting motor can rise straight because of THC can not receive the collision signal.

Service Support Spirit

- ◆ P14: Brake acceleration. This parameter can set deceleration time value when motor stop to work. This parameter is bigger, deceleration can become faster, the time of motor stop work can become shorter. The biggest parameter is 50.
- ◆ P15: Reversion acceleration. Speed adjust step and length when motor turn contrary. When motor speed is changing or motor turn positive become turn contrary. It can change speed value by change this parameter, the bigger parameter can make reversal transition speed become more and more smaller. We set it as 100(it is the biggest value), user can adjust this parameter on the basis of specific condition when they used THC.
- ◆ P16: Arc voltage delay time of setting. After arc start command is send and delaying in this time has finished, THC start sampled the arc voltage value. This time can be used for avoiding to sample severe and waved arc voltage when arc start to work.
- ◆ P17: Torch lifting time after starting up. When THC is starting up, the time of promoting the lifting motor. It can avoid some condition that the distance between torch and workpiece is nearer. If user do not pay attention to make equipment start to work and move the torch, it will lead to happen collision. Lifting torch can avoid this accident happen after starting up.
- ◆ P18: The time of promoting the spear after torch has accomplished. After torch has accomplished, torch can lift a height. When arc start test, if user loosened the button named **【ARCON TEST】** , torch can lift in this time.
- ◆ P19: Torch lifting time when arc start to work. When piercing delay time is not set to 0, THC can used this parameter and send a commend of arc start. Arc start is working, at the same time, torch is lifting in this time. Before piercing has accomplished, torch can descend a height which it is the same with promoting height. It can named dynamic pierce function similarly. When piercing is working, torch need promote a height, it can avoid dress get into torch head. If dynamic pierce lifting times that we set is 0, torch can not promote when arc start is working.
- ◆ P20: The time of descending rapidly during the dual speed IHS. During the dual speed IHS, at first, motor descend by fastest speed in this time. Then motor descend by lowest speed until collision has happened(lowest speed= fastest speed /4). If user set it as 0, motor will descend by fastest speed/4.

Service Support Spirit

“Hxx” submenu listing:

High/low level of input display in red LED. If LED display 0, input is low level.

If LED display 1, input is high level.

Parameter number	Parameter range	Yellow LED	Red LED	Remark
H01	0 or 1	H01	0	The signal level condition of CNC_AUTO/MANUAL
H02	0 or 1	H02	0	The signal level condition of CNC_THC_UP
H03	0 or 1	H03	0	The signal level condition of CNC_THC_DN
H04	0 or 1	H04	0	The signal level condition of CNC_IHSAON
H05	0 or 1	H05	0	The signal level condition of CNC_EXAON
H06	0 or 1	H06	0	The signal level condition of UP_LIMIT
H07	0 or 1	H07	0	The signal level condition of DN_LIMIT signal
H08	0 or 1	H08	0	The testing signal of Torch retaining cap collision
H09	0 or 1	H09	0	The testing signal of proximity switch

“Lxx” submenu listing:

High level effective or low level effective of input signal is displayed in red LED. If user set it as 0, the effective level of input is low. If user set it as 1, the effective level of input is high. When low level is effective and the actual level of input signal is 0, it means this signal has happened. For example, when user set “L05” as 0 and “H05” display 0, it means this signal is useful at now.

Service Support Spirit

It can explain that the arc start signal which has IHS and send by CNC is useful. If “H05” display 1, it mean CNC can not send arc start signal which has IHS.

Default of input is low level effective. User can change it on the basis of actual condition.

Parameter number	Parameter range	Default of parameter	Yellow LED	Red LED	Remark
L01	0 or 1	0	L01	0	The effective level of CNC_AUTO/MANUAL.
L02	0 or 1	0	L02	0	The effective level of CNC_THC_UP.
L03	0 or 1	0	L03	0	The effective level of CNC_THC_DN.
L04	0 or 1	0	L04	0	The effective level of CNC_IHSAON.
L05	0 or 1	0	L05	0	The effective level of CNC_EXAON.
L06	0 or 1	1	L06	1	The effective level of UP_LIMIT.
L07	0 or 1	1	L07	1	The effective level of DN_LIMIT.
L08	0 or 1	0	L08	0	The effective level of testing torch retaining cap collision signal.
L09	0 or 1	0	L09	0	The effective level of testing proximity switch signal

Note: Default of motor limit L06、L07 is Set up as 1, it means motor limit switch should be set as shut form. User can change it on the basis of actual condition. If lifting motor do not has limit switch, it do not connect line but they need set L06、L07 as 0.

Service Support Spirit

2.4 Motor drive current

This system adopts the integrated motor driver chip with protection function, it has perfect over-current, Over temperature protection.

The current peak of motor drive can be up to 5A.

2.5 Working process

The cutting process with the initial positioning

When art start signal which it connect by CNC is IHSAON, THC can start IHS at first: torch can decline until collision has happened. Then torch can be promoted to the original location level and THC can send a commend to make arc start work, it make arc start relay close, plasma power source start arc start. After arc start is working successfully and piercing delay time is over, THC send a successful signal of arc start to CNC. CNC start cut, if THC is working in the automatic allow state and CNC has sent auto control height signal, THC can work in the automatic control height state. During torch work, if user pressed the button named **【AUTO】**, THC can quit allow condition automatically. Auto control height is stopped, and torch height remain the same. If user pressed the button named **【AUTO】** again, THC will recover allow condition automatically. THC can continue control height automatically. After torch has accomplished, CNC close IHSAON signal, THC can auto make torch promote a height which we set.

The cutting process without the initial position

When art start signal which it connect by CNC is EXAON, THC can not start IHS and send a commend to make arc start work straight. It make arc start relay close, plasma power source start arc star. After arc start is working successfully, and piercing delay time is over, THC send a successful signal of arc start to CNC. CNC start cut, if THC is working in the automatic allow state and CNC has sent auto control height signal, THC can work in the automatic control height state. During torch work, if user pressed the button named **【AUTO】**, THC can quit allow condition automatically. Auto control height is stopped, and torch height remain the same. If user pressed the button named **【AUTO】** again, THC will recover allow condition automatically. THC can continue control height automatically. After torch has accomplished, CNC close IHSAON signal, THC can auto make torch promote a height which we set.

Chapter3 Port connection

THC has voltage divide pierce in their interior, with CNC、dc motor、 arc start switch、 proximity switch, etc. Points linking piece put in the case, and the whole point of metal shielding encapsulation, voltage divide piece can be connected directly to the plasma power source arc pressure and protective cap collision detection circuit, etc.

3.1 The case view

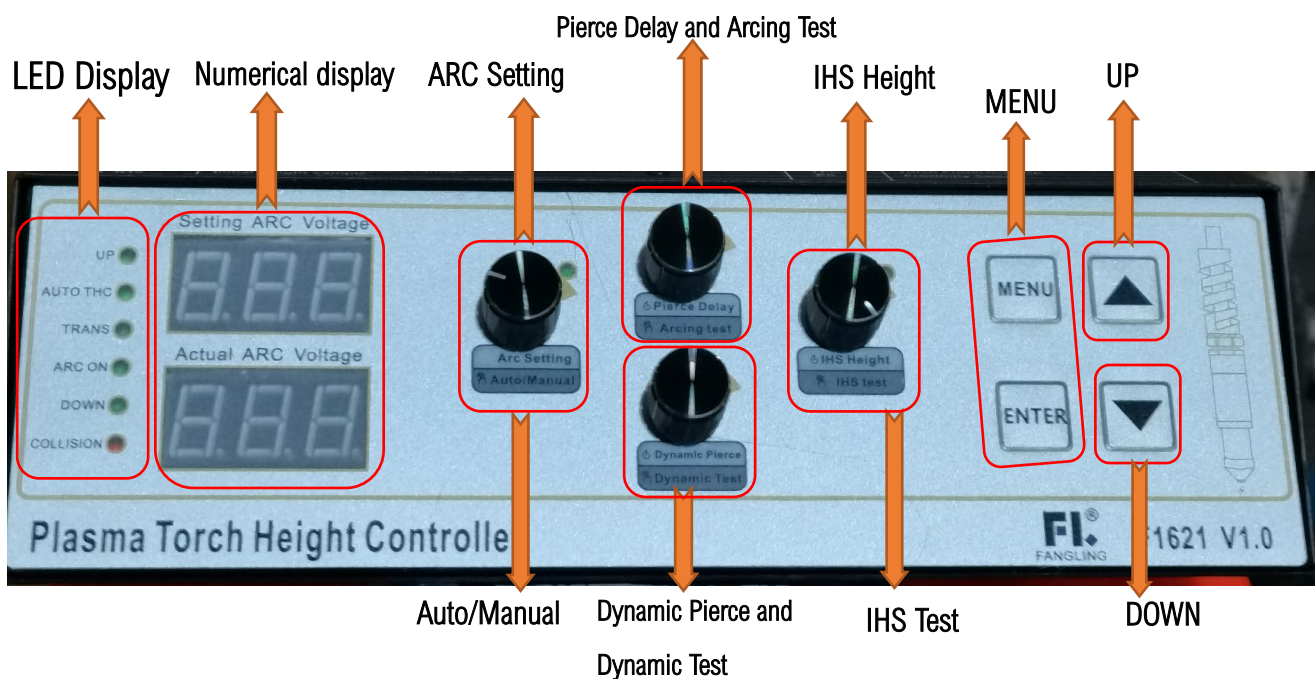

Figure 3. The positive view of mainframe

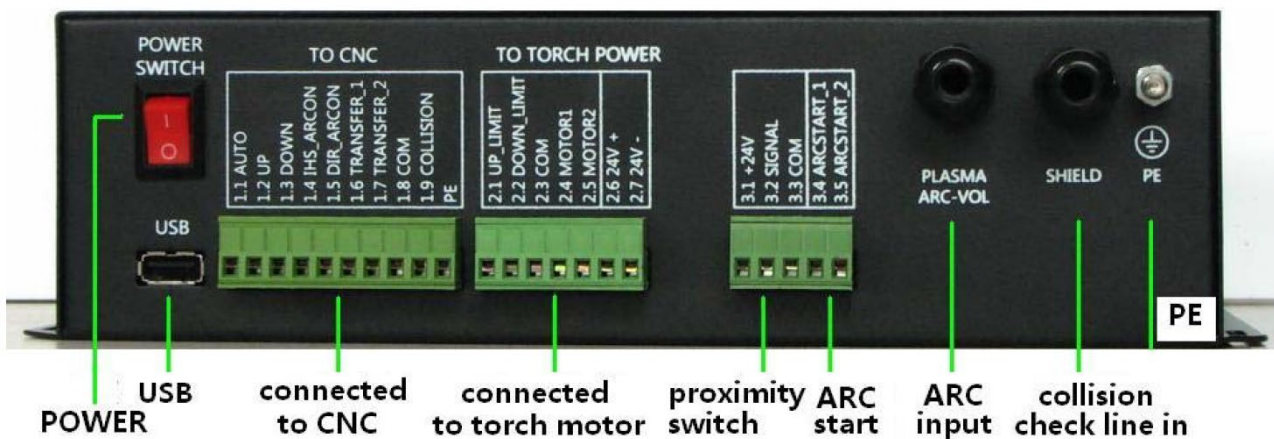

Figure 3.2 The rear view of mainframe

Service Support Spirit

3.2 Chassis port

3.2.1 CNC port

THC connect with the CNC by a socket which has 10 pin, the diagram below pin definition:

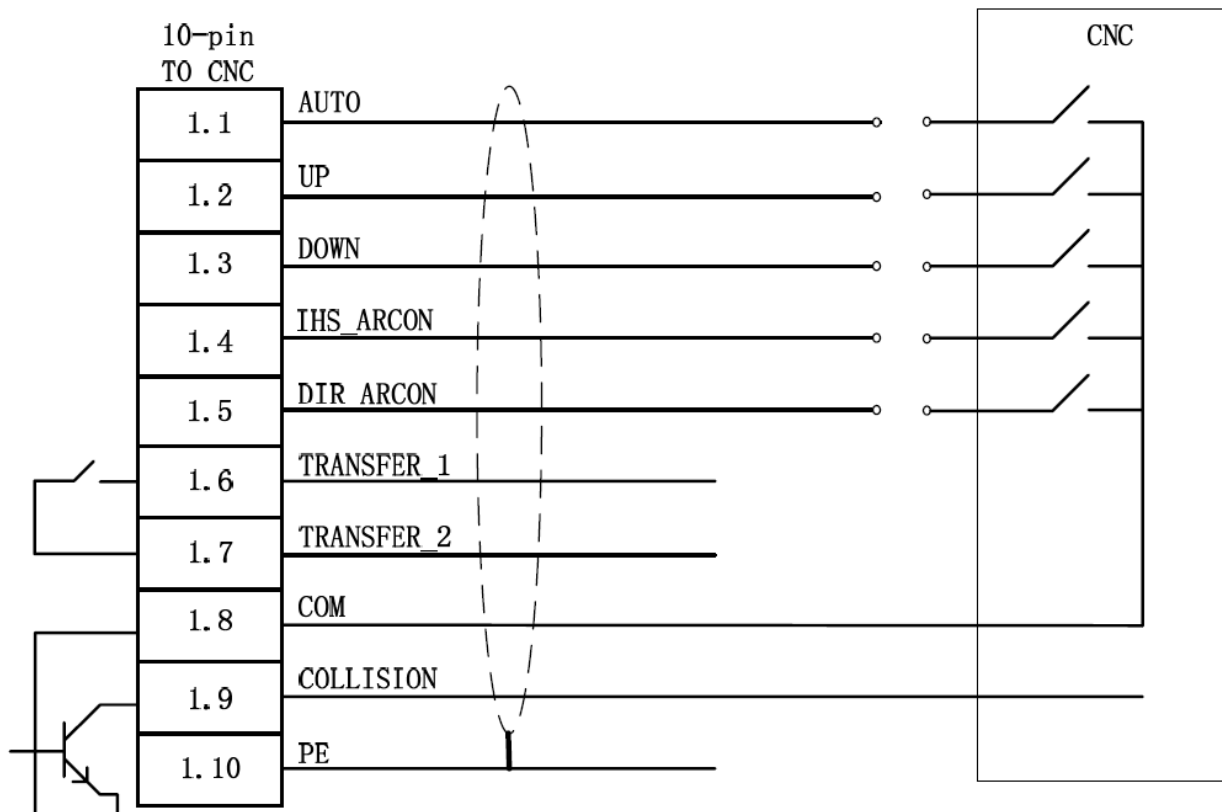

Figure 3.3 The port of connecting with CNC

Warning:

1. The signal which connected with CNC is insulated by optocoupler , and the effective level is low (user can change it to make high level effective)
2. TRANSFER_1、TRANSFER_2 are a disconnected contactor of relay. After piercing has accomplished, if CNC detect arc voltage effectively, the contactor will be close. When arc start is not effective, the contactor keep disconnected state.

Service Support Spirit

The socket which has 10 pin description:

Pin Number	Signal	Content
1.1	AUTO	Enabling height control automatic: in genal, the effective level is low level. It connect the signal of closing height control, the corner signal, angle of low speed signal and so on.
1.2	UP	The signal of controlling torch lift: in genal, the effective level is low level. CNC control THC by this port, and control torch lift.
1.3	DOWN	The signal of controlling torch decline: in genal, the effective level is low level. CNC control THC by this port, and control torch lift.
1.4	IHSARCON	IHSARCON The IHSARCON signal: in genal, the effective level is low level. When CNC make torch work, it can output low level to this port, THC can start IHS and make arc start work.
1.5	DIRARCON	The DIRARCON signal: in genal, the effective level is low level.
1.6	TRANSFER1	The output piercing signal of finished: after arc start has worked and piercing delay time is over, if CNC detect arc voltage effectively, it will make TRANSFER1 and TRANSFER2 close. The contactor is a disconnected contactor of relay. The port is a feedback signal which arc start has worked successfully.
1.7	TRANSFER2	
1.8	COM	Pin named 1.1、1.2、1.3、1.4、1.5、1.9 use this port as control signal com, it connect with signal of CNC.
1.9	COLLISION	Input collision signal: opened and leaky output, it need connect the load exteriorly. If THC detect signal which collision has happened, this pin will output level signal. After CNC has receive collision signal, torch can be stopped to work.

Service Support Spirit

When it connect with CNC(F2000), the connection diagram as follows:

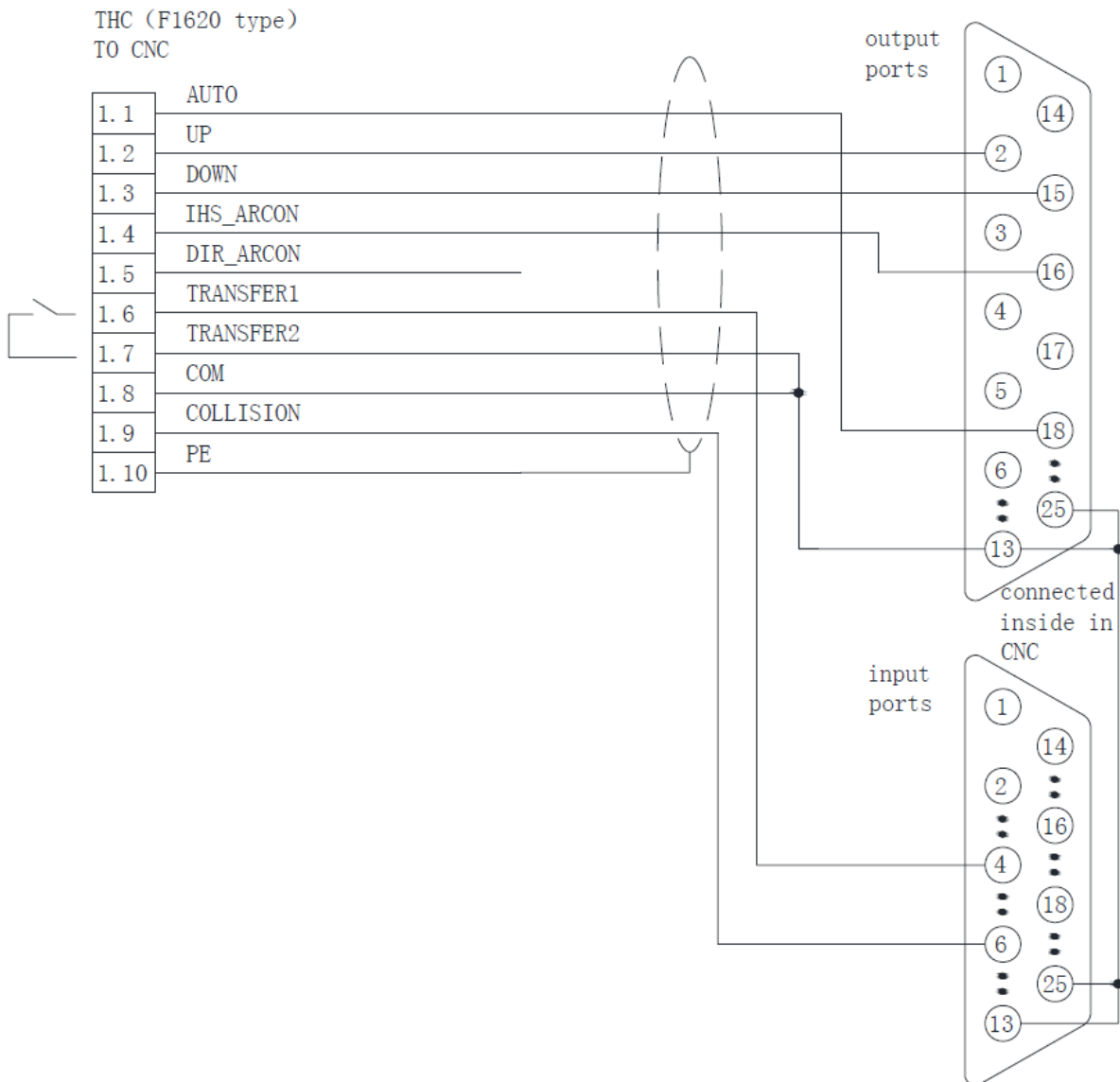

Figure 3.4 the connection diagram of connecting with CNC

3.2.2 Power supply, motor and motor limit port

THC use dc 24V to provide voltage, the biggest power supply scope is 22V-34V, the power of dc 24V is depended on the motor power, the power of dc supply should be greater value-added between motor power and 5W.

Service Support Spirit

Power supply port, motor and motor limit port use the same set of plug. The plug wiring defined as follows:

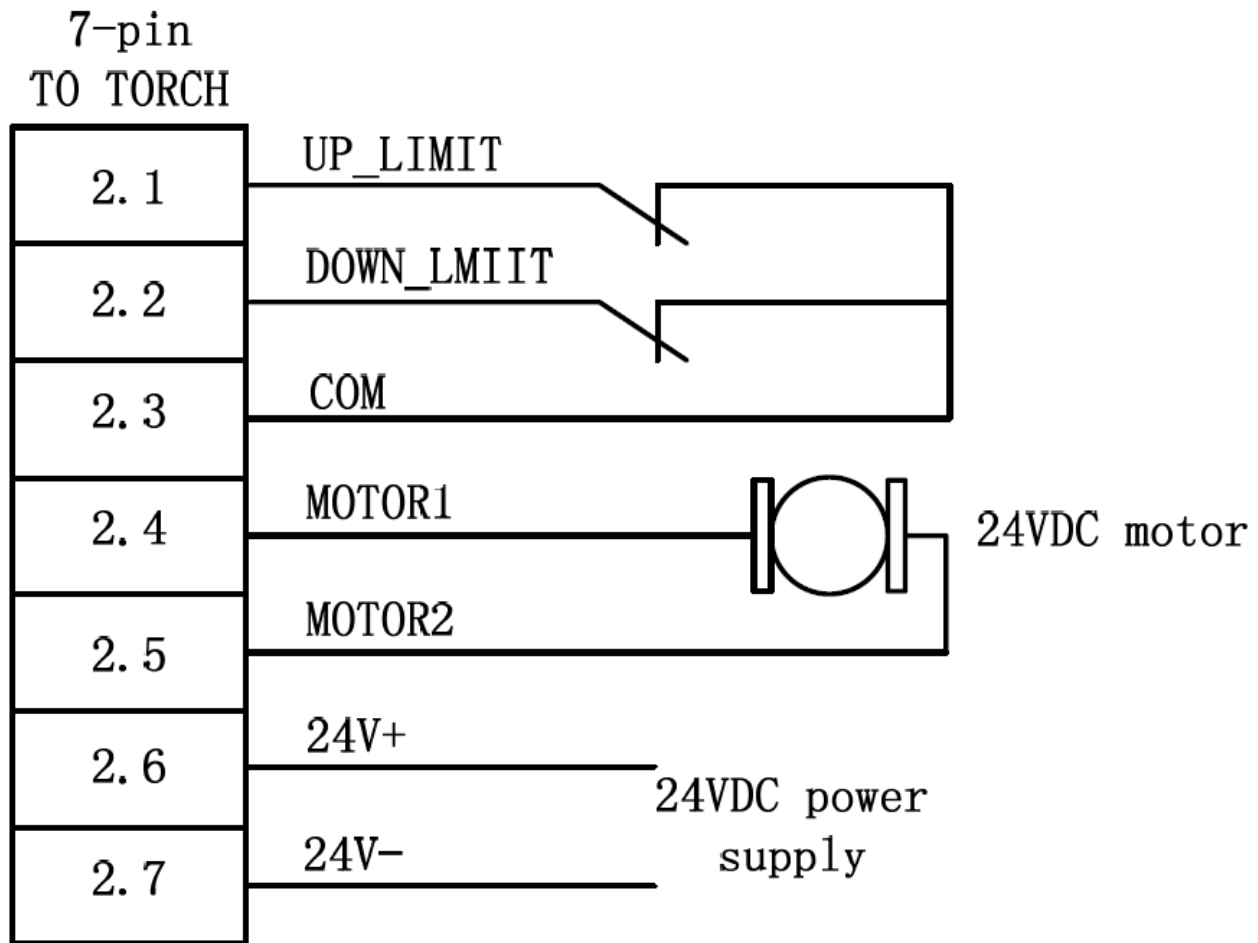

Figure 3.5 Power supply, motor and motor limit port

In genal, motor limit switch keep close. The limit switch is keep close in THC. Therefore, the parameter L06, L07 should be set as 1. If user make switch keep open, the parameter L06, L07 should be set as 0.

The socket which has 7 pin description:

Pin Number	Signal	Content
2.1	UP_LIMIT	UP_LIMIT input of dc motor. When contactor keep close and limit switch do not work, pin2.1 and pin2.3 is connected. When motor has collided limit switch, limit switch start work, pin2.1and pin2.3 is disconnected.

Service Support Spirit

2.2	DOWN_LIMIT	DOWN_LIMIT input of dc motor. When contactor keep close and limit switch do not work, pin2.1 and pin2.3 is connected. When motor has collided limit switch, limit switch start work, pin3 and pin5 is disconnected.
2.3	LIMIT COM	Pin2.3, limit COM
2.4, 2.5	MOTOR PORT(MOTOR1,MOTOR2)	DC motor driver output, it connect positive and negative electrode of 24V dc motor, the biggest motor power is 100W. If user want to change DC motor direction of rotation, it will be came true by exchange wiring between MOTOR1 and MOTOR2. It also will be came true by enabling parameter P12.
2.6	POWER SOURCE PORT(24V+)	The positive input dc 24V
2.7	POWER SOURCE PORT(24V-)	The negative input dc 24V

3.2.3 Arc start port and proximity switch position port

THC connect arc start switch and proximity switch by a socket which has 5 pin.

Pins are defined as follows:

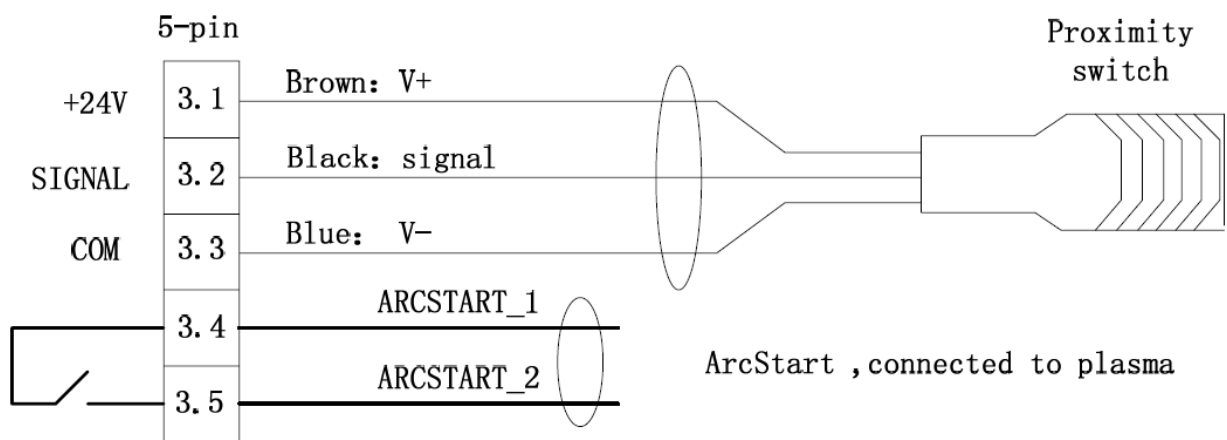

Figure 3.6 arc start relay and proximity switch port

Service Support Spirit

The socket which has 5 pin description:

Pin Number	Signal	Content
3.1	+24V	The power source anode of proximity switch.
3.2	SIGNAL	The signal input terminal of proximity switch.
3.3	COM	The power source cathode of proximity switch
3.4, 3.5	Arc Start Port (ARCSTART_1, ARCSTART_2)	This is normally open contactor of relay. When CNC send arc start commend, the contactor can close and plasma power source start make arc start work.

Arc start port use normally open contacts of relay: during arc start and torch are working, relay contactor can keep close. It can keep open in other condition. The relay contactor capacity is 10A/250VAC, if work voltage and work current of arc start control circuit are exceeded this rated value, please use relay to augment capacity. Otherwise, system will not work steadily.

In side THC, A 200mA recoverable fuse is installed at the power supply of proximity switch, to avoid damage of power when proximity switch failed.

The proximity switch of THC is NPN(or PNP) type open-drain proximity switch. User can set it by the switch on voltage divide board. If the 2-bits switch is "ON", user should use NPN proximity switch. If the 2-bits switch is "OFF", user should use PNP proximity switch. The default set of the 2-bits switch is "ON".

NOTICE: in the new version of hardware, the 2-bits switch is canceled. User can use NPN or PNP type open-drain proximity switches directly only by changing the "L09" parameter if needed.

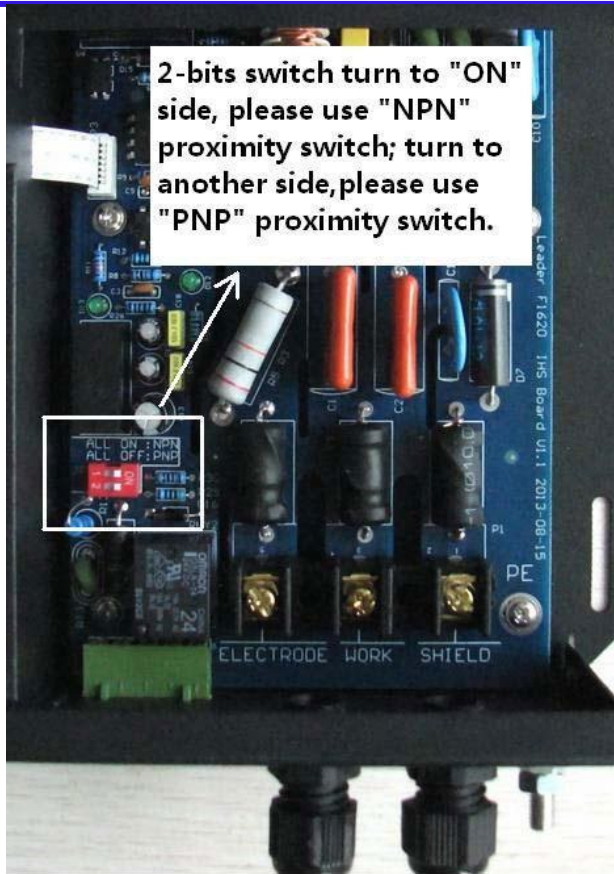

Figure 3.7 The proximity switch view upon voltage divide board



Figure 3.8 The proximity switch view upon voltage divide board

Service Support Spirit

If user wants to use two NPN proximity switch, they should connect it as above drawing. Two proximity switch connection method is shown as follows. By this connection, any one of them is effective, THC can receive this signal.

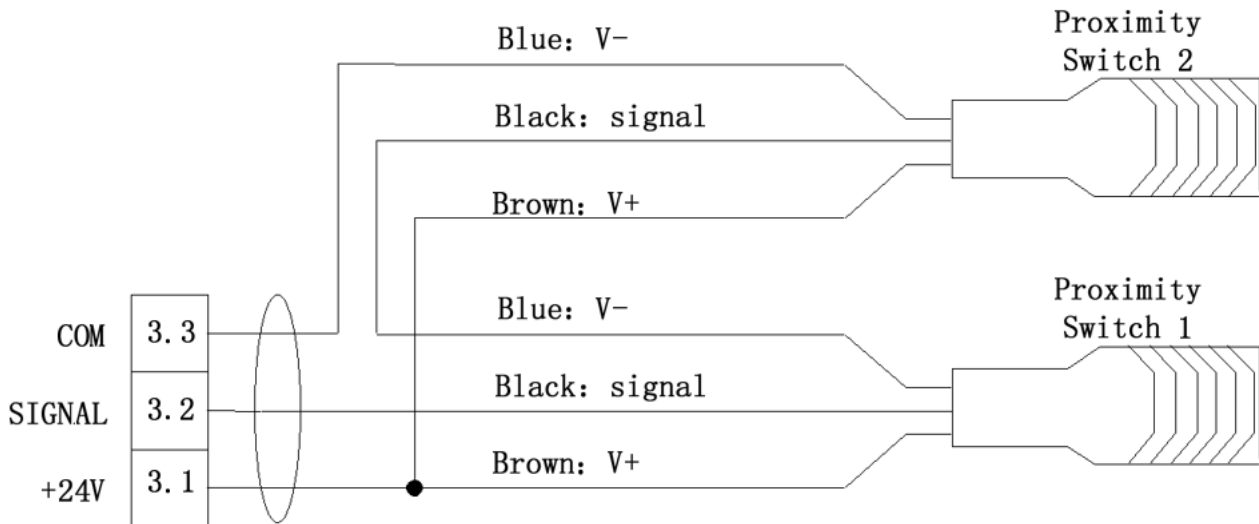

Figure 3.9 Two proximity switch connection method

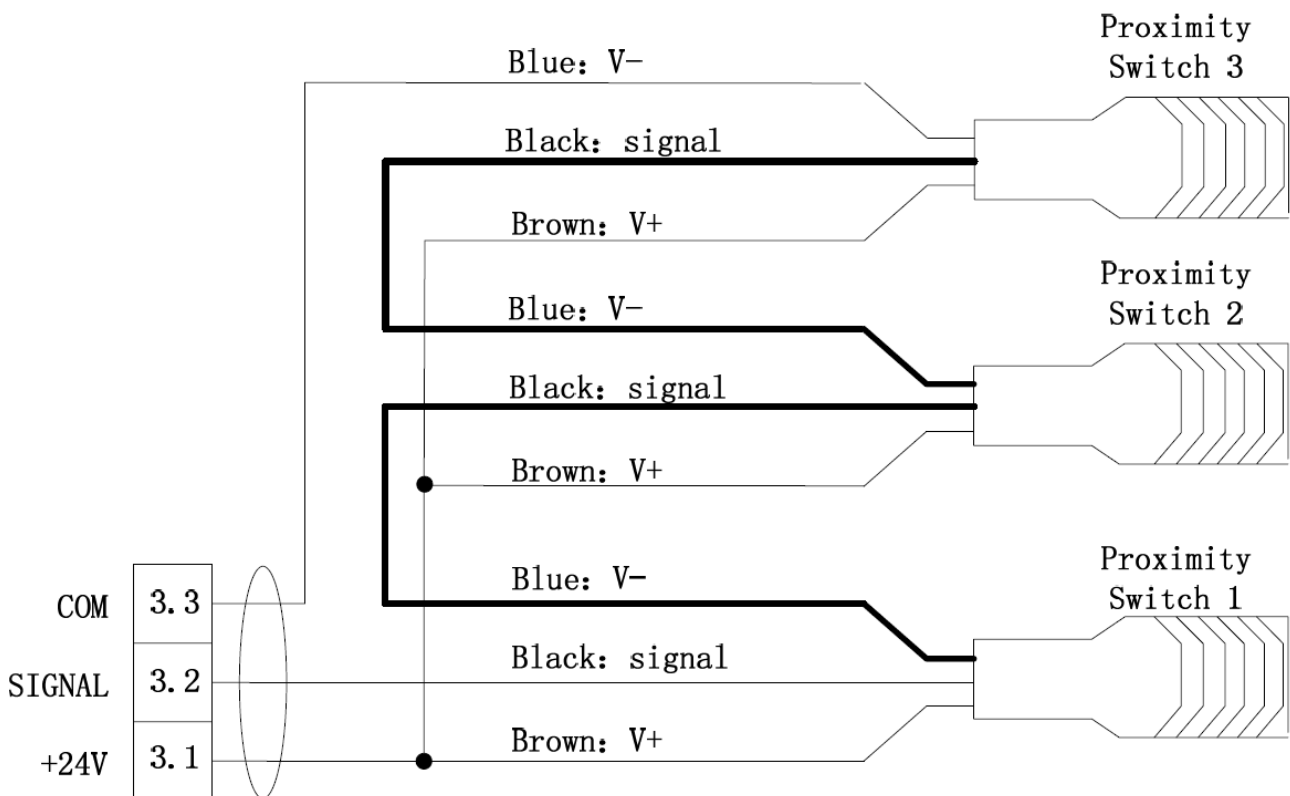

Figure 3.10 Three proximity switch connection method

Warning:

Service Support Spirit

1. It is better for user to connect NPN proximity switch as above drawing. By this method, any one of them effective, THC can receive this signal.
2. When user use a NPN normally open proximity switch(or some NPN normally open proximity switch), L09 should be set as 0.
3. When proximity switch is breaking away from, the red indicator light of proximity switch can be . At the same time, the collision indicator in THC panel can be lighted.
4. In genal, if collision and torch incline do not happen, the red indicator light of proximity switch will be lighted straight.

3.2.4 USB port

THC has a function which can make firmware procedure upgrade. User can use USB flash disk, make it connect this USB port, then it can make firmware procedure upgrade.

The upgrade method:

- 1) Copying the firmware program named “pthc. bin” or “F1621.bin” to the root directory of USB flash disk.
- 2) Power off THC, and then insert this USB flash disk.
- 3) Power on THC. After THC power on, the green nixie tube may display
- 4) “PHC”, the red nixie tube has 3 seconds countdown. Before the end of the countdown, pressing the button named **【MENU】** can enter into the upgrade mode. At the same time, the green nixie tube can display “UPD” and start flashing, it means THC wait for confirmation to upgrade. If user do not press the button named **【MENU】** before the end of the countdown, THC will start work normally after the end of the countdown. If user do not press the button named **【MENU】** before the end of the countdown, and user presses the button named **【+】**, THC will skip the countdown and enter into the normal working condition.
- 5) When the button named **【MENU】** is pressed, after entering into upgrade model, the green nixie tube display “UPD” and start flashing, it means THC wait for confirmation to upgrade. Then if the button named **【OK】** is pressed, THC start update. At the same time, the green nixie tube display “UPD” but it do not start flashing, the red nixie tube display upgrade progress by digital form. When it display 8, it means program has been updated by 8%. When it display 16, it means program has been updated by 16%.
- 6) After pressing the button named **【MENU】** and THC has entered into upgrade model, If user do not press the button named **【MENU】** and user presses the button named

Service Support Spirit

- 【 + 】 , THC will skip the upgrade condition of waiting and enter into the normal working condition. If waiting for upgrade and do not press any key, after 20 seconds, THC will end the upgrade condition of waiting and enter into the normal working condition.
- 7) When the red nixie tube displays 100, it means program has been updated by 100% and upgrade is successful. After upgrade is successful, the nixie tube display “SUC” and start flashing three times, then automatic restart THC.
 - 8) After upgrade has been successful, it do not need to do any action. THC can restart automatically, then after 3 seconds countdown, THC enter into normal working condition.
 - 9) After THC restart and enter into normal working condition, user can pull up USB flash disk.
 - 10) After THC firmware program upgrade is accomplished, the parameter of the original set will not change and can use normally.

Service Support Spirit

3.3 voltage divide port

3.3.1 arc voltage port

Portable THC (TYPE F1621) use voltage divide board to detect plasma arc voltage and torch remaining cap collision signal. The connection as follows:

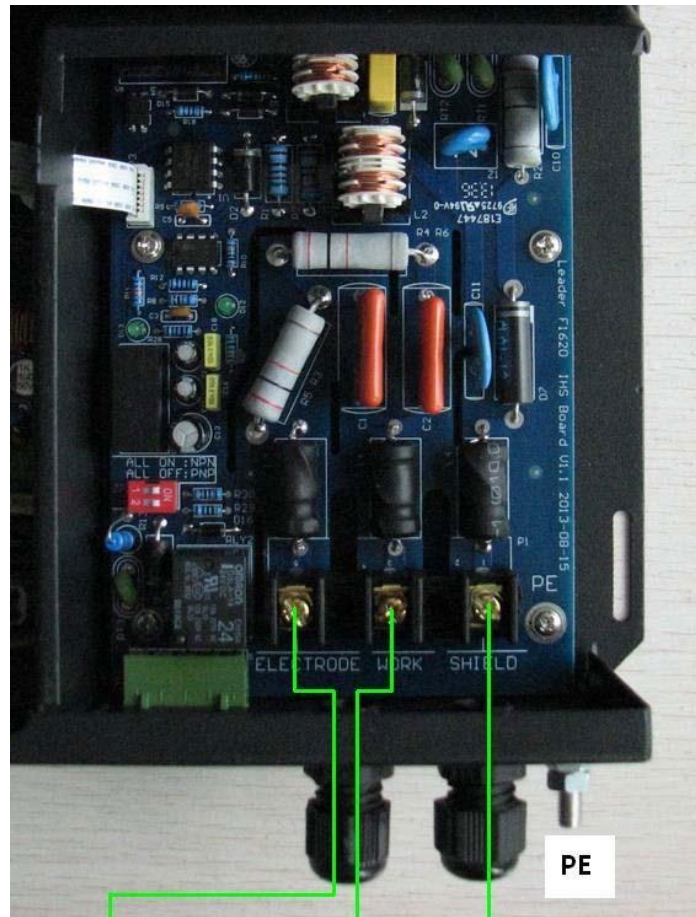

ARC- :	ARC+ :	connected to
connected	connected to	protecting shield
to electrode	work pole	to check
pole of plasma	of plasma	collision

Figure 3.11 voltage divide board port and wiring

When THC detect plasma arc voltage, it detect plasma by voltage divide circuit. After arc voltage(which plasma output)/100, import it into THC mainframe. As shown above:

ELECTRODE port (the screen printing word named ELECTRODE in PCB) connect with plasma arc voltage cathode.

WORK port (the screen printing word named WORK in PCB) connect with plasma arc voltage anode.

Service Support Spirit

SHIELD port (the screen printing word named SHIELD in PCB) connect with torch retaining cap collision detection wiring.

The plasma power source anode is connected with GND, cathode is connected with torch nozzle, and the voltage of nozzle is negative voltage. During torch work, the absolute value of the arc voltage is greater than 100V. Because voltage is higher and interference is bigger, it is necessary to control by quarantining voltage divide. THC voltage divide board use voltage divide circuit which ratio is 100: 1, the arc voltage range which we can measure is 0V~660V.

Warning: the plasma power arc voltage sampling cable need use HVSC, plus-n-minus should not be connected contrary. If arc voltage plus-n-minus is connected contrary, auto height control will not work. Plasma power source arc voltage wiring need connect with wiring pile in plasma power source output, it do not connect with torch and work piece, it can avoid disturbing by the high frequency.

3.3.2 torch retaining cap detection circuit port

THC can has two way of IHS :

- ◆ Torch retaining cap IHS;
- ◆ Proximity switch IHS.

For torch retaining cap IHS, the torch retaining cap need connected to SHIELD port by high voltage cable. The connection as follows:

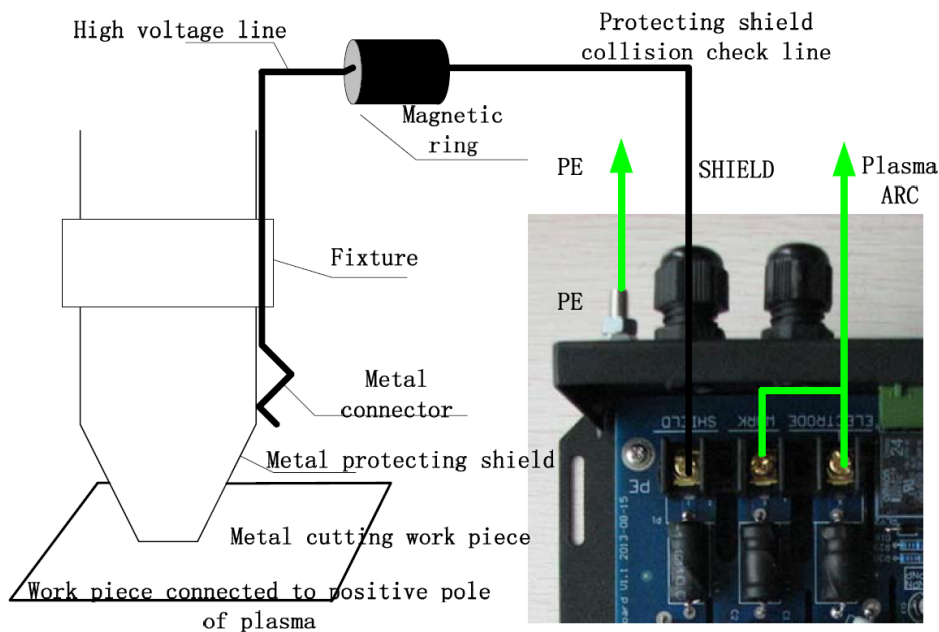

figure 3.12 voltage divide board wiring diagram

Service Support Spirit

Work process: THC receives arc start signal from CNC, lifts torch down right away until torch retaining cap collide the workpiece. When retaining cap touches workpiece, collision detection circuit can be connected. THC can receive this collision signal right away and lift torch up to the set height. Then THC control plasma power source start to work.

- 1) During torch retaining cap is detecting collision, user need notice some matter:
- 2) Cable connect to retaining cap via “SHILED” position, at the same time, in high voltage wires, user can twine a magnetic ring near the pressure plate, and user can make cable twine some rounds in magnetic ring. It can avoid high-frequency interference which plasma arc voltage produced usefully.
- 3) When Cutting material and workpiece connect with plasma power source anode, they are short circuit, and ensure the circuit is low impedance. Wiring usually can accomplish it. it do not need treat specially, because it has guaranteed the short circuit when plasma power source anode and workpiece has connected.
- 4) GND named PE must be connected well, GND size $>4\text{mm}^2$.
- 5) When torch retaining cap contact with workpiece, tangent resistance $<20\text{k}\Omega$.
Otherwise, torch retaining cap collision detection circuit can not work because of impedance is too large. It is especially important for rusty steel note, if the steel rust is serious, user should clean the steel surface before torch start work, remove rust layer.
- 6) Torch retaining cap collision detection circuit just need a signal line of collision detection, circuits use wiring which arc voltage sample, so it can save a high voltage cable.

Warning: Torch retaining cap collision detection circuit and the proximity switch detection circuit can work at the same time, one of them can complete positioning when they has detect collision signal. In genal, torch retaining cap IHS signal can be triggered at first and accomplish fixed position. But when workpiece has rusted oxide or has the protective insulation, torch retaining IHS is invalid. If torch retaining cap IHS can not complete, THC will use proximity switch to complete positioning.

If the wiring of torch retaining cap IHS is connected true, torch retaining cap IHS will work usefully. And user can choose whether use proximity switch on the basis of parameter. When user set parameter P13 as 1, they should use proximity switch to detect collision. When user set P13 as 0, they should not use proximity switch to detect collision.

Service Support Spirit

3.4 The total wiring diagram

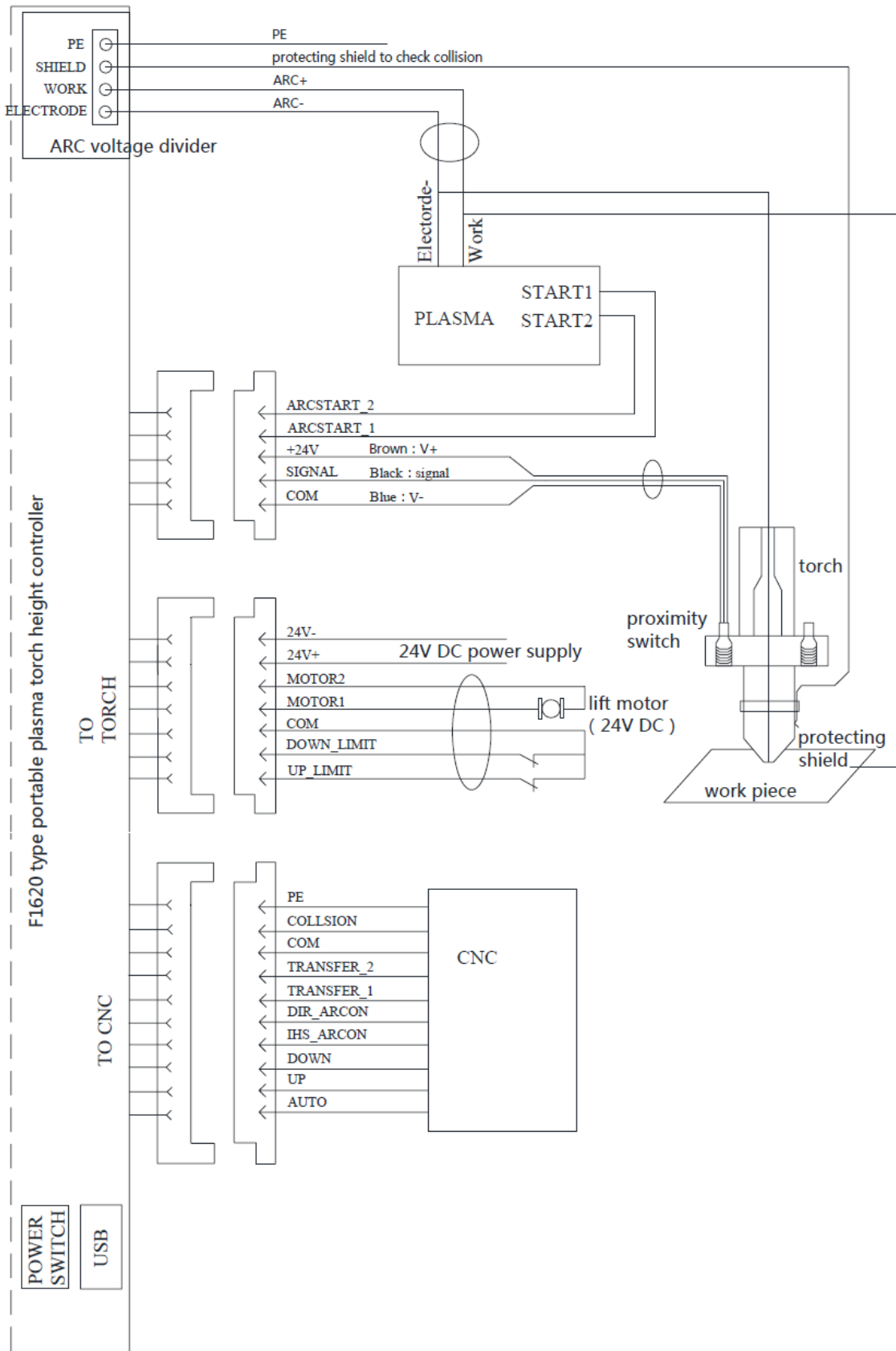

Chapter 4 common problems

During THC work, user can encounter some problem and solution as follows:

NO.	Failure phenomenon	Reason	Solution
1.	Nixie tube do not display	Power source module has problem	Check whether the power source connection is steady.
2.	Motor do not turn	Blocking signal make it lock	1. Check whether UP_LIMIT/DOWN_LIMIT signal make it lock 2. Over-current protection make motor driver chip lock.
3.	After motor turn, it do not work	Motor chip is protected by over-current action.	1. Check whether mechanical structure is stuck
4.	After THC power on, the motor has been rising	Collision signal can make motor rise all the time	1. Check whether proximity switch wiring is connected well, check whether parameter P13、L09 or L08 is set well. If wiring is connected true and parameter is set true, the red indictor is lighted when proximity switch close 2. Check whether proximity switch is damaged 3. Check whether torch retaining cap positioning wiring is connected well. In genal, there do not has collision signal when torch retaining cap do not contact with steel.
5.	Arc voltage control is unstable		1. Check whether the grounding is true. 2. Check whether plasma power source cooling water is oozed. 3. Sensitivity coefficient P07 setting is too large
6.	Before IHS has accomplished, plasma can make arc start work right away	It always happen in the case of arc start signal control	Extend CNC positioning waiting time

Service Support Spirit

7.	After IHS has accomplished, auto arc start is closed.	Plasma power source can not start arc start, or arc start relay is not closed	1. Coming back THC arc start relay wiring, make two wiring which control plasma power source start arc start connect, observe whether plasma can make arc start work normally. 2. If plasma can make arc start work normally, user should check whether THC arc start relay can be closed normally(when the button named 【ARCON TEST】 is pressed, arc start relay should be closed).
8.	Torch can not start arc start		1. Confirming the plasma power source is working 2. Check whether IHS height is too high(or low) 3. Check torch part which it is easy to damage. 4. When torch retaining cap is sensing, electrode and the nozzle has scum which made by cutting, it can make short circuit happen.
9.	When CNC make torch start work, torch decline immediately.	When CNC make torch start work and arc voltage is too high, if auto height control start work, torch will decline immediately.	1. Increasing arc voltage setting value. 2. Extending the time which CNC start auto height control need spend. 3. Check whether the corner low speed signal of CNC or auto signal is normal, in genal, auto height control signal is not joined before torch cut a few millimeters.
10.	After arc has shifted and piercing has accomplished, plasma make arc start stop to work.		1. Delay time is too long.(before torch machine move, torch stay time is too long in piercing position, plasma is easy to make arc start stop to work)

Service Support Spirit

11.	When auto IHS work, torch is not uplifted after it collide steel plate.	THC do not receive collision signal or IHS height is too small.	1. Check whether collision signal can work normally(check whether proximity switch or torch retaining cap can reflect the collision situation normally). If it can not reflect the collision situation normally, IHS will not be accomplished. 2. Check whether positioning height time setting is too small, if this setting value is too small, gun will not be uplifted.
12.	Torch is easy to collide steel plate during torch work	Arc voltage setting is too small	Increasing the arc voltage setting point
13.	During auto height control work, torch is easy to vibrate	The sensitivity is too high	Reducing the sensitivity coefficient P07 slightly
14.	When touch work in the relatively steep slope, arc voltage follow speed is too small	The sensitivity is too small, or lifting motor speed is too small	1. Increasing sensitivity coefficient P07 slightly 2. Changing lifting motor which has faster speed
15.	Arc breaking is happened during torch work, CNC do not make torch stop work right away	After plasm arc breaking has happened, arc voltage do not decline right away. After THC receive this signal, it think arc start is working normally, and do not send arc breaking signal	CNC can receive arc feedback signal which make by plasma

Service Support Spirit

16.	The green nixie tube display LIC after starting up	Data storage go wrong	User should post it back our factory, we can repair it.
17.	When program is upgrading, after pressing the enter key, the machine do not work and do not accomplish the upgrade.	USB read-write speed does not match	1. Please upgrade again after powering off .2. Please upgrade again after replacing the USB flash disk.