

How to connect MaxPro200 with Stinger

- ◆ The MaxPro200 connect to Stinger, 6 wires need to be connected.
- ◆ The Machine connect terminal:

Machine	Aviation plug	Terminal No.	Description
Stinger connect terminal	2-core	START	The CNC plasma arc initiation signal
		START	
	2-core	TRANS/FEEDBACK	Notifies the CNC that an arc transfer has occurred
		TRANS/FEEDBACK	
	2-core	ARC+	The CNC arc voltage signal
		ARC-	

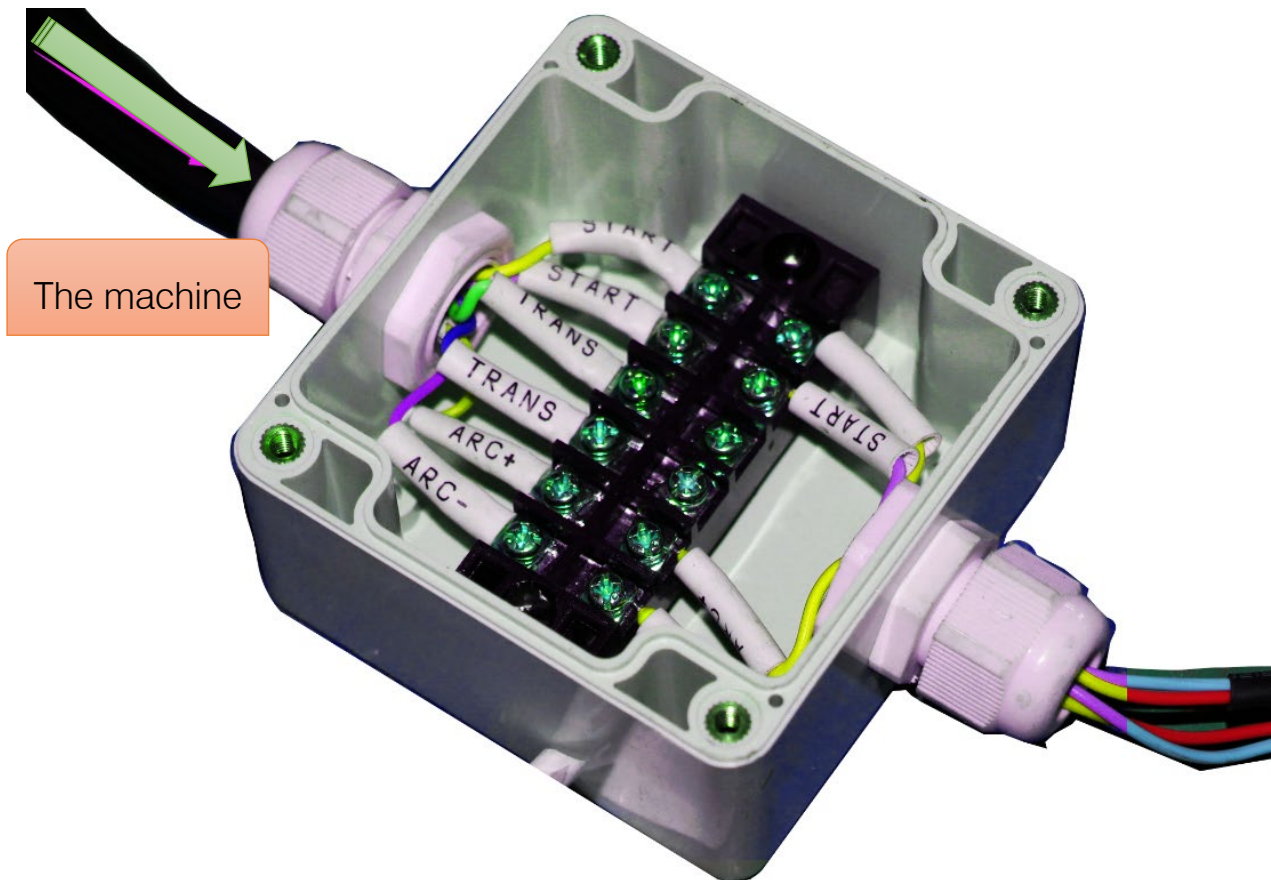

Service Support Spirit

■ MaxPro200 connect terminal:

Note: The customer needs to connect the power cable according to the actual plasma models.

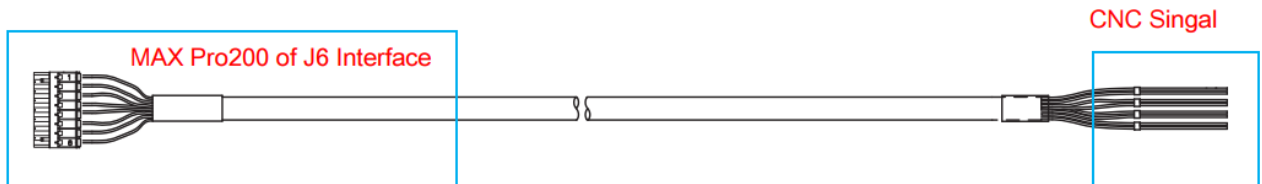

Power supply end					CNC end	
Wire color	Pin number	Input/Output	Signal name	Function	Input/Output	Notes
Orange	1	Input	Start +	The CNC initiates preflow, and if the hold input is not active, continues with the plasma arc. The system will stay in preflow if the hold input remains active.	Output	Start
White	2	Input	Start -		Output	
Brown	3	Input	Hold +	The CNC delays plasma arc initiation. This signal is normally used in combination with the start signal to synchronize multiple torches.	Output	1 and 3
White	4	input	Hold -		Output	
Black	5	Output	Motion +	Notifies the CNC that an arc transfer has occurred and to begin machine motion once the CNC's pierce delay has timed out.	Input	feedback
White	6	Output	Motion -		Input	
Red	7	Output	Error +	Notifies the CNC that an error has occurred.	Input	2
White	8	Output	Error -		Input	

J6 Interface location:

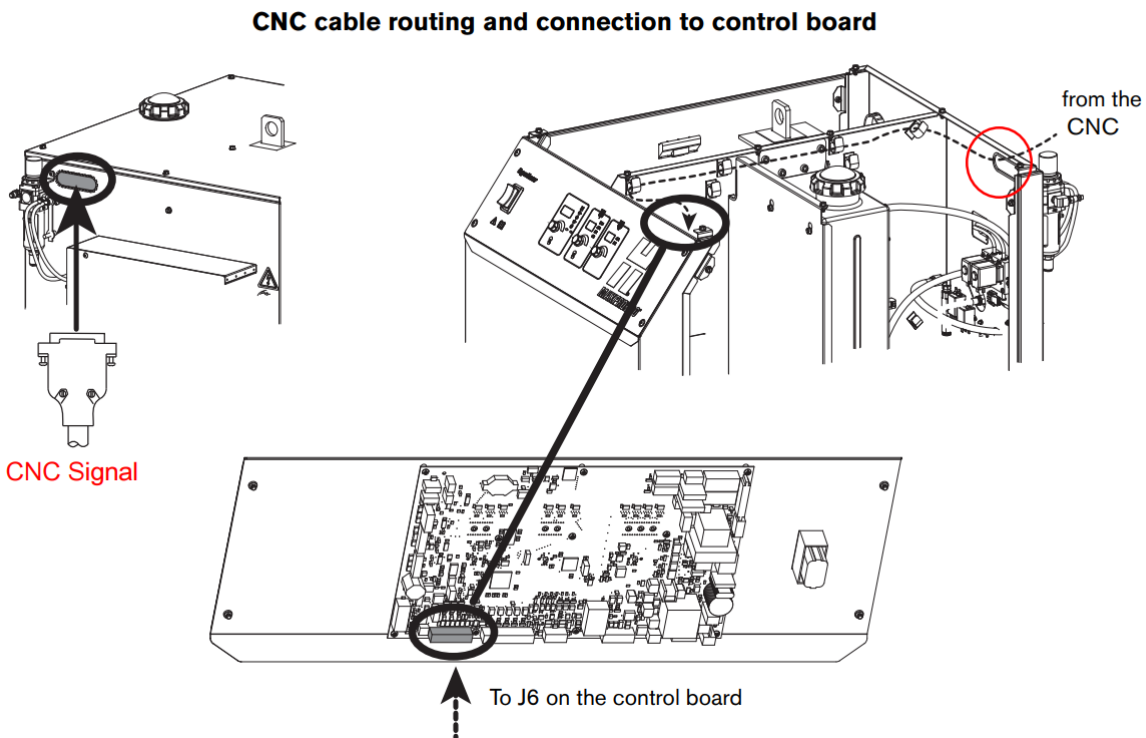

◆ Plasma source original arc pressure position:

1. Turn OFF all power to the system.

2. Locate the chopper board.

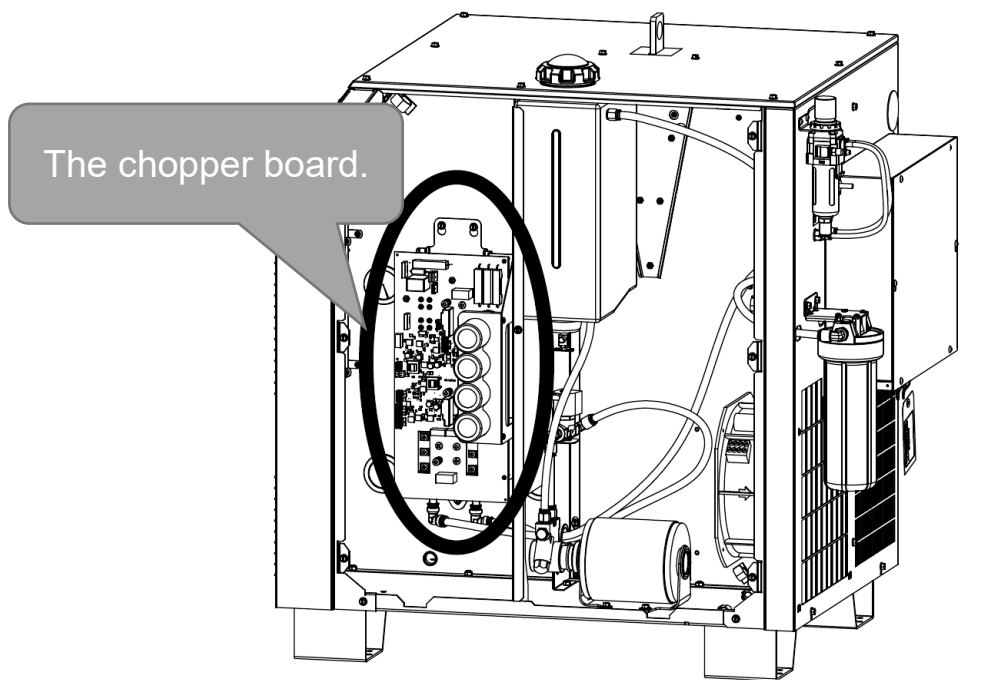

3. The position of J7 (H9, NOZZLE) and J9 (H8, WORK) on the chopper board

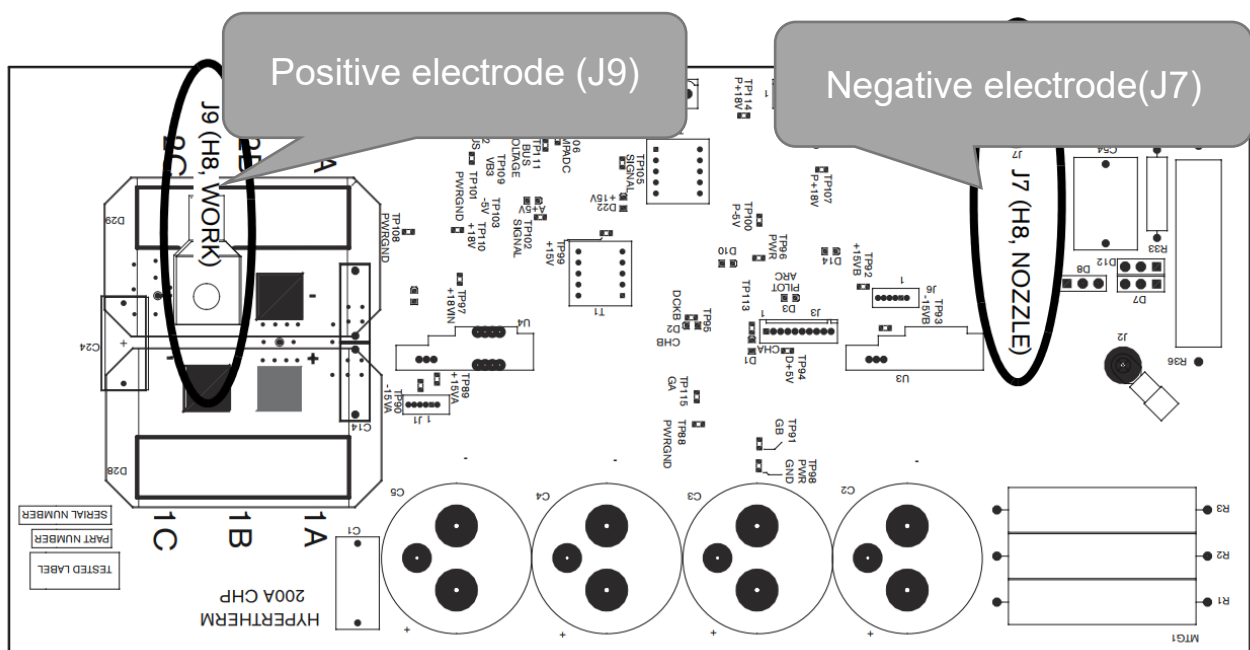

NOTES 1: Positive electrode (work—J9) of Plasma power is connected the ground wire. and check it by multimeter. If **【work-J9】** is not connected the ground wire, please find the other port.

Negative electrode(J7) of Plasma power is connected the plasma torch. and check it by multimeter; If **【J7】** is not connected the ground wire, please find the other port.

Service Support Spirit

◆ Cable connecting method:

	Terminal No.	Corresponding interface of Max Pro200	The interface position
Stinger connect terminal	START	3 Input Start	MaxPro200 Interface
	START	4 Input Start	
	TRANS/FEEDBACK	12 Output Transfer	
	TRANS/FEEDBACK	14 Output Transfer	
	ARC+	Positive electrode (work—J9)	
	ARC-	Negative electrode(--J7)	

◆ Connect the machine to the plasma signal with terminal blocks:

