

Service Support Spirit

How to connect Powermax105&125 with Scout2

- ◆ The Plasma connect to Scout-2, 2 cable need to be connected.
- ◆ Scout 2 connect terminal:

	Terminal No.	
Scout-2 connect terminal	START	The CNC plasma arc initiation signal
	START	
	ARC+	The CNC arc voltage signal
	ARC-	

Machine signal definition:



- ◆ POWERMAX105&125 connect terminal:

Note: The customer needs to connect the power cable according to the actual plasma models.

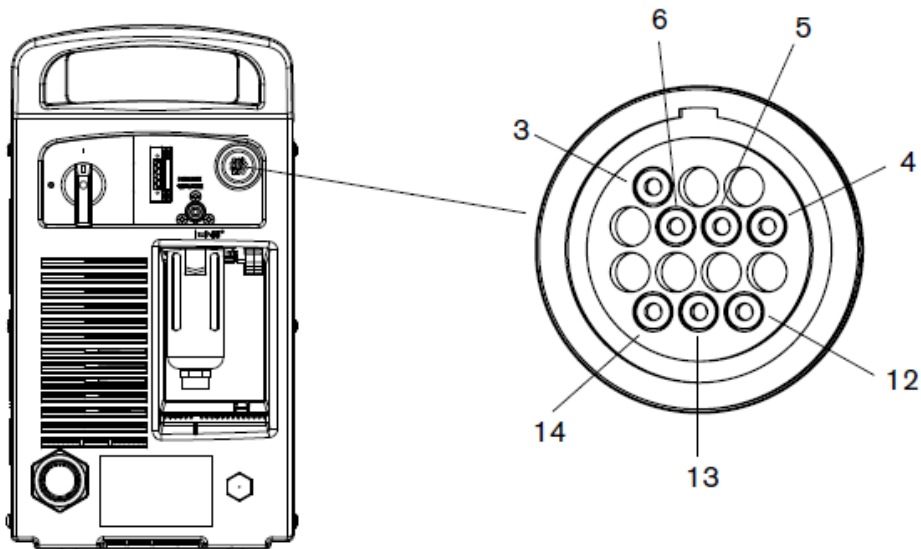

Plasma interface signals:

Machine interface cable signals

Refer to the following table for the cable signal details when connecting the power supply to a torch height controller or CNC controller with a machine interface cable.

Signal	Type	Notes	Connector sockets	External cable wires	Internal cable wires
Start (start plasma)	Input	Normally open. 15 VDC open circuit voltage at START terminals. Requires dry contact closure to activate.	3	Green	Black
			4	Black	Red
Transfer (start machine motion)	Output	Normally open. Dry contact closure when the arc transfers. 120 VAC / 1 A maximum at the machine interface relay.	12	Red	White
			14	Black	Green
Voltage divider	Output	Divided arc signal of 20:1, 21.1:1, 30:1, 40:1, 50:1 (provides a maximum of 16 V).	5 (-)	Black (-)	Black (-)
			6 (+)	White (+)	Red (+)
Ground	Ground		13		Green/yellow

The original arc voltage position of the plasma power supply:

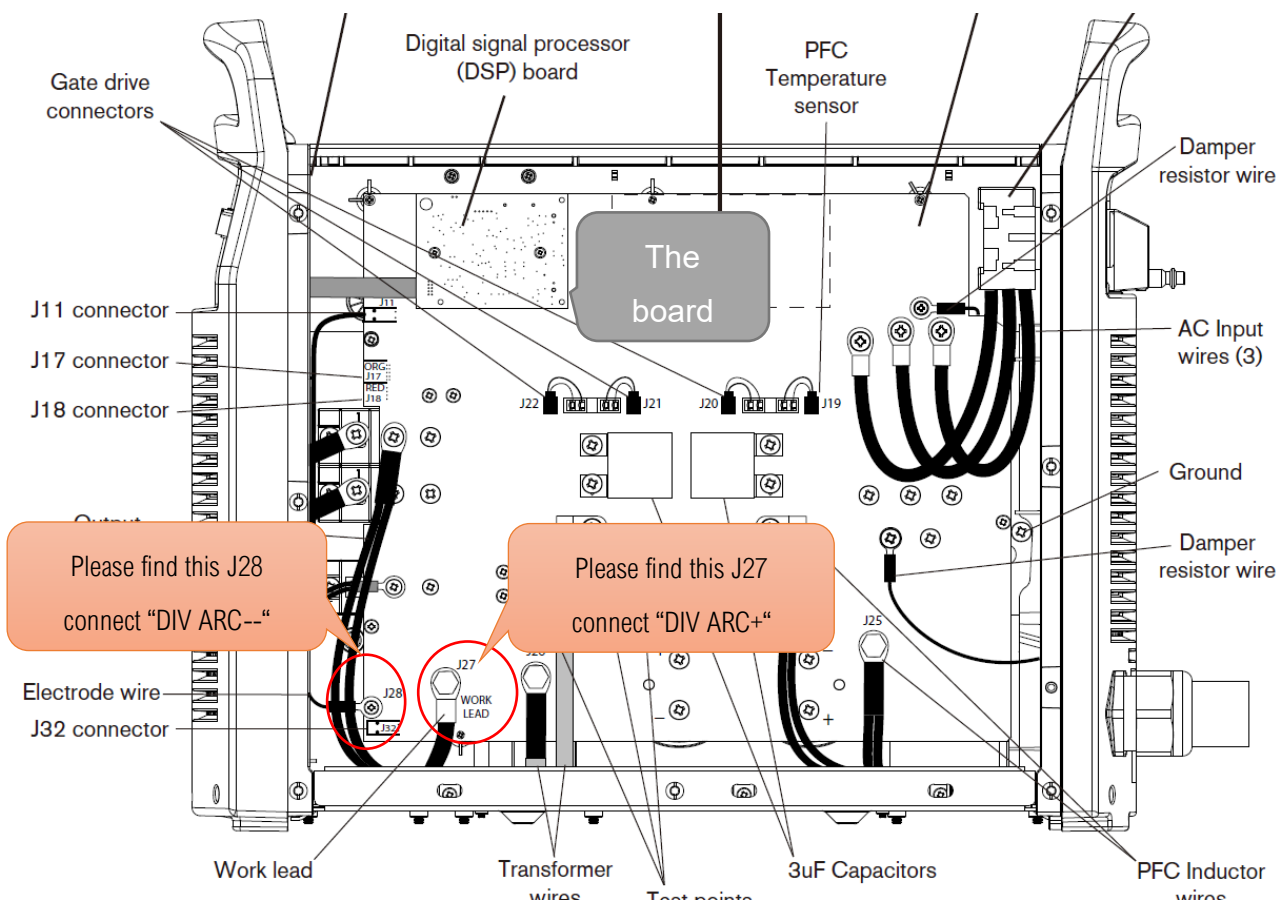
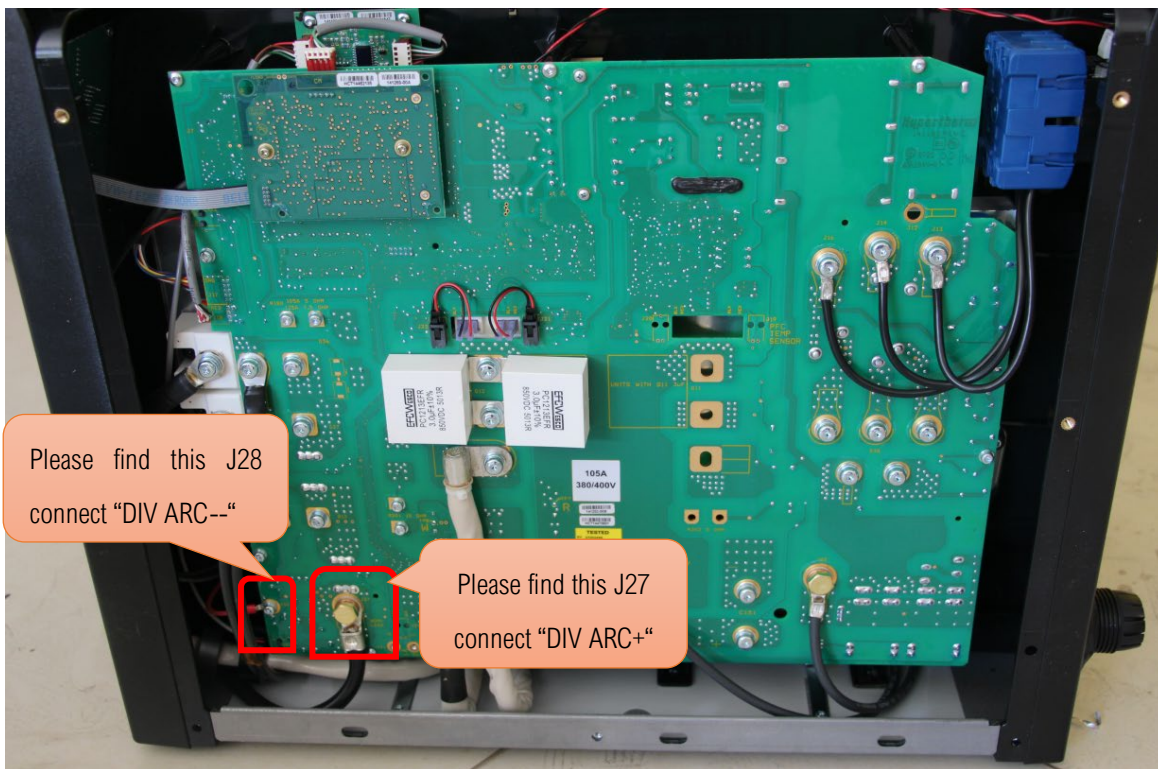

Service Support Spirit

NOTES 1: Positive electrode (work--J27) of Plasma power is connected the ground wire. and check it by multimeter. If 【work】 is not connected the ground wire, please find the other port.

Negative electrode(J28) of Plasma power is connected the plasma torch. and check it by multimeter; If 【J28】 is not connected the ground wire, please find the other port.

◆ Cable connecting method:

	Terminal No.	Corresponding interface of POWERMAX105&125	The interface position
Scout2- connect terminal	START	3 Input Start	POWERMAX105&125 Interface
	START	4 Input Start	
	ARC+	Positive electrode (work--J27)	
	ARC-	Negative electrode(--J28)	

◆ Signal connection of arc starting



Service Support Spirit

- ◆ Signal connection of ARC+/ARC-

