

How to connect Powermax65&85 with Tube-S&Tube-mini

- ◆ The Powermax65&85 connect to Tube-S&Tube-mini, 4 wires need to be connected.
- ◆ The Machine connect terminal:

Machine	Aviation plug	Terminal No.	Description
Tube-S&Tube-mini connect terminal	2-core	START	The CNC plasma arc initiation signal
		START	
	2-core	ARC+	The CNC arc voltage signal
		ARC-	

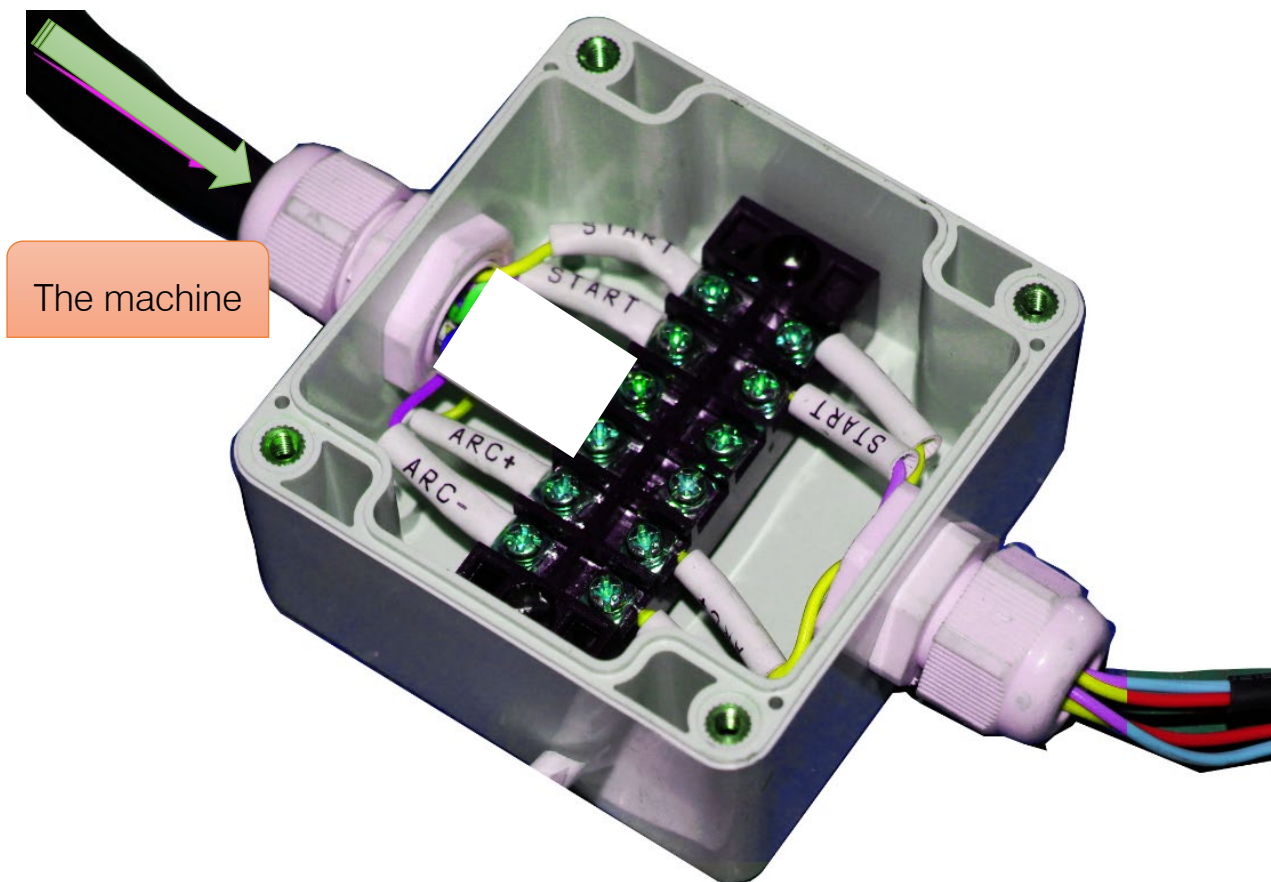

Service Support Spirit

◆ POWERMAX65&85 connect terminal:

Note: The customer needs to connect the power cable according to the actual plasma models.

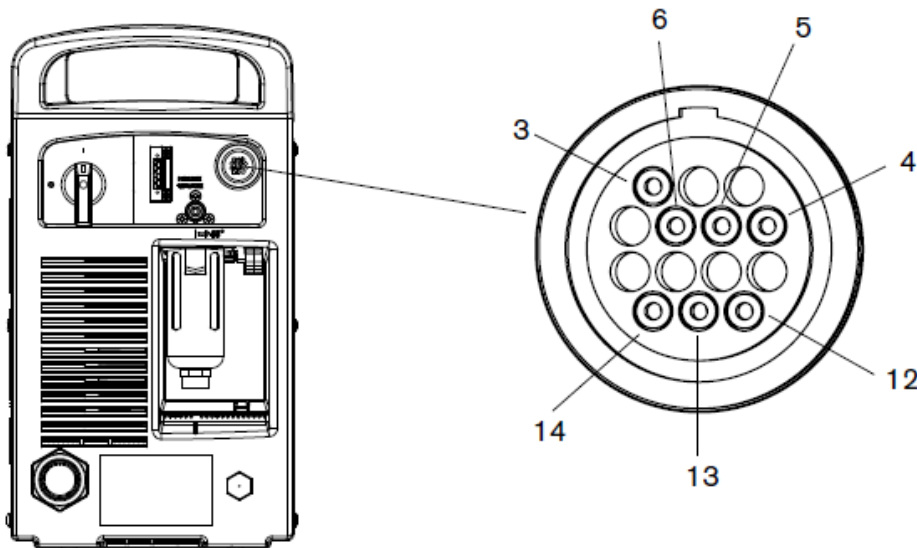

Plasma interface signals:

Machine interface cable signals

Refer to the following table for the cable signal details when connecting the power supply to a torch height controller or CNC controller with a machine interface cable.

Signal	Type	Notes	Connector sockets	External cable wires	Internal cable wires
Start (start plasma)	Input	Normally open. 15 VDC open circuit voltage at START terminals. Requires dry contact closure to activate.	3	Green	Black
			4	Black	Red
Transfer (start machine motion)	Output	Normally open. Dry contact closure when the arc transfers. 120 VAC / 1 A maximum at the machine interface relay.	12	Red	White
			14	Black	Green
Voltage divider	Output	Divided arc signal of 20:1, 21.1:1, 30:1, 40:1, 50:1 (provides a maximum of 16 V).	5 (-)	Black (-)	Black (-)
			6 (+)	White (+)	Red (+)
Ground	Ground		13		Green/yellow

The original arc voltage position of the plasma power supply:

Interior, power board side (380/400V CE)

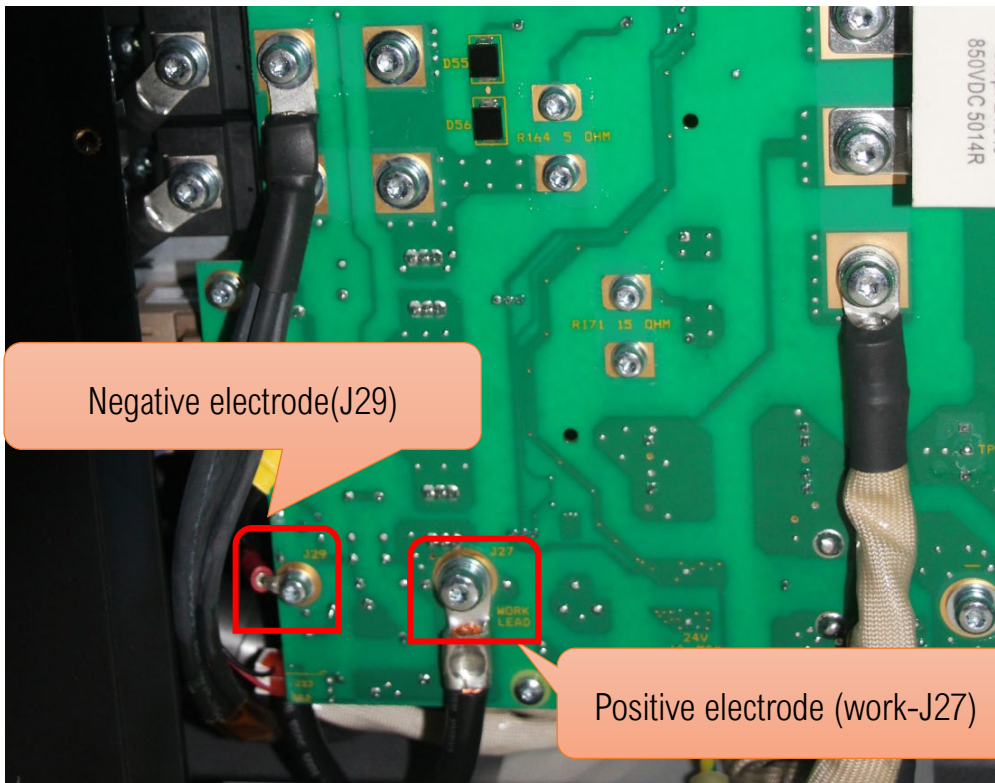
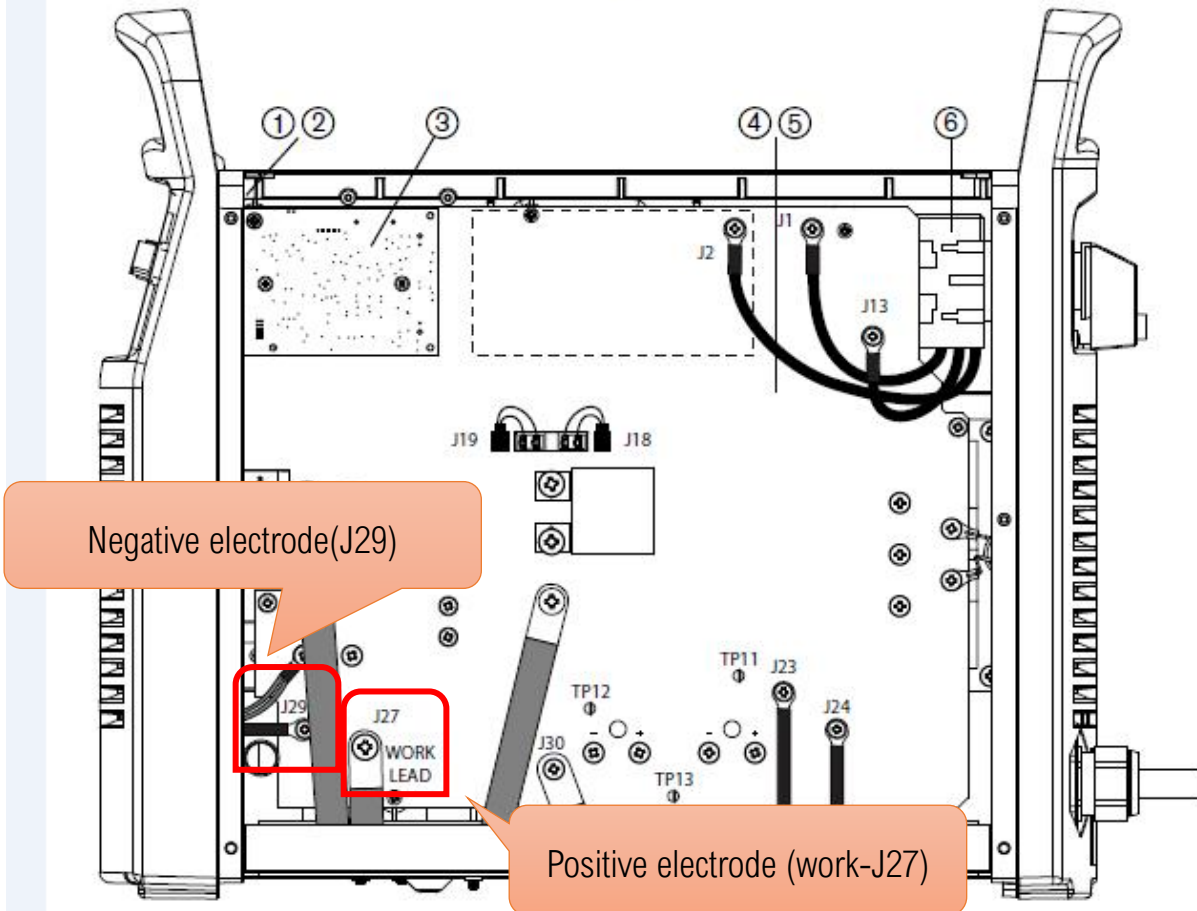

Service Support Spirit

NOTES 1: Positive electrode (work--J27) of Plasma power is connected the ground wire. and check it by multimeter. If 【work】 is not connected the ground wire, please find the other port.

Negative electrode(J29) of Plasma power is connected the plasma torch. and check it by multimeter; If 【J29】 is not connected the ground wire, please find the other port.

◆ Cable connecting method:

	Terminal No.	Corresponding interface of POWERMAX65&85	The interface position
Tube-S&Tube-mini connect terminal	START	3 Input Start	POWERMAX65 &85 Interface
	START	4 Input Start	
	TRANS/FEEDBACK	12 Output Transfer	
	TRANS/FEEDBACK	14 Output Transfer	
	ARC+	Positive electrode (work--J27)	
	ARC-	Negative electrode(--J29)	

◆ Connect the machine to the plasma signal with terminal blocks:

