

ARCBRO®

SDF30A THC

SDF30A THC User's Manual



Operator Manual

ARCBRO | Revision 2 | English

Date of issue: August, 2019

Unique Solution

WWW.ARCBRO.COM

Contents

| | |
|---|----|
| 1. Preface..... | 3 |
| 1.1. Object..... | 3 |
| 1.2. Important Announcement..... | 4 |
| 1.3. Caution..... | 5 |
| 2. General Description..... | 6 |
| 2.1. Technical Characteristics..... | 6 |
| 2.2. Main Technical Parameters..... | 7 |
| 3. Installation..... | 8 |
| 3.1. Mechanical Installation..... | 8 |
| 3.2. Electrical Installation & Connection..... | 11 |
| 3.2.1 Control Modes of External Switches..... | 11 |
| 3.2.2 Electrical Installation of THC with Capacitance Detecting Mode..... | 12 |
| 3.2.3 Electrical Installation of Arc-voltage THC..... | 16 |
| 3.3. Function Description of Voltage Dividing Plate..... | 19 |
| 4. Process..... | 22 |
| 4.1 Operation process..... | 22 |
| 5. Application Guide..... | 24 |
| 5.1. Manual Operation..... | 24 |
| 5.2. Automatic Operation..... | 24 |
| 6. Controller Panel..... | 26 |
| 6.1. Control Setting..... | 26 |
| 6.2. Operation Panel..... | 27 |
| 6.3. Description of Displayed States..... | 28 |
| 7. Description of Initial Positioning Function..... | 30 |
| 7.1. Positioning Mode..... | 30 |
| 7.2. Setting of Positioning Height..... | 30 |
| 7.3. Process..... | 31 |
| 8. Trouble Shooting..... | 32 |
| 8.1 Common faults and how to check..... | 32 |

1. Preface

For both flame cutting and plasma cutting, the stability of distance (height) between cutting nozzle and plate during cutting process is vital, such distance (height) can directly affect the cutting speed and cut quality.



Fig. 1-1 SF-HC30A Flame/Plasma Cutting Torch THC

1.1. Object

The SF-HC30A Flame/Plasma Cutting Torch THC is a specially designed cutting-torch automatic height-control block with integration of mechanical lifting and electrical control for portable flame and plasma cutter.

The SF-HC30A Flame/Plasma Cutting Torch THC is easy to use, simple to commissioning and cheap, have our traditional feature “performance of imported

Service Support Spirit

products, price of domestic products”. It is the ideal supporting product for welding-cutting equipment manufacturers.

1.2. Important Announcement

There may be difference between real product and manual picture of SF-HC30A Flame/Plasma Cutting Torch THC, the actual product is standard. The product or accessories are subjected to changes without prior notice. Please refer to the updated information.

- ◆ Please read the safety warnings and notes carefully, to avoid the dangerous accidents for misuse.
- ◆ Before installing and using the product, operate strictly according to the detailed description of product manual, to assure correct application.
- ◆ If the SF-HC30A Flame/Plasma Cutting Torch THC and such manual contents are used illegally, it does not represent the views of our company; we will refuse to take the legal responsibility, the users should be responsible for all consequences.
- ◆ The safety warning items protect the human and property from damage.
- ◆ During using the SF-HC30A Flame/Plasma Cutting Torch THC, if there is any quality issue, the users can call ARCBRO .
- ◆ Any information in such manual can not be duplicated, reprinted or used without our written permission, and the violators should take all responsibility for the caused loss.

1.3. Caution

For safety operation, achieving designed control accuracy and avoiding any damage to such product, carefully read and strictly follow the following cautions. The installation persons should be technicians in related industry or with related experience.

Carefully read such manual before installation.

- ◆ Confirm the power supply has same specifications as required.
- ◆ It is forbidden to install, insert or draw the plus with power-on.
- ◆ The installation location should be as far as possible from the heat sources.
- ◆ The controller enclosure should be well grounded, to avoid the electric-shock or affect normal operation of controller.
- ◆ The cut steel plate should be well grounded, and well connected with the controller enclosure, to ensure the accuracy of height control.



Note: If the controller enclosure and the cut steel plate are not well grounded, the height control can not work normally.

- ◆ Handle carefully, do not impact or shake intensely to avoid damaging the product..
- ◆ Do not arbitrarily disassemble the cutting-torch THC or change its internal structure, to avoid occurrence of accidents or failures.

2. General Description

2.1. Technical Characteristics

- **Use stepper motor instead of traditional DC motor**

The SF-HC30A Flame/Plasma Cutting Torch THC adopts the stepper-motor control technology and subverts the traditional DC-motor height adjusting mode; the new control mode is quick and smooth, and greatly increase the product service life.

- **Integration of Mechanical Lifting Device and THC**

The integrated design of detector, controller and driver realizes high integration of product; the adjusting travel is 10 cm.

- **All-digital Technology**

The circuit adopts the SMT without any adjustable elements; the all-digital technology assures the high reliability of product.

- **Application in Severe Environment**

The closure adopts the air-, interference-, water- and moisture-proof design, is especially suitable for the severe environment of high temperature and high electromagnetic interference of flame cutting and plasma cutting.

- **Various Interfaces, Easy to Use**

The interfaces are simple and easy to control, suitable for all numerical control system of flame / plasma cutting, and can also use alone.

2.2. Main Technical Parameters

- ◆ Power Supply: DC 24V \pm 2 V 3 A.
- ◆ Applicable Motor: 17hs (42) Serial Stepper Motor.
- ◆ Manual Adjusting Scope: 0~100 mm.
- ◆ Automatic Height Adjusting Control Scope: 3~30 mm.
- ◆ Automatic Height Adjusting Speed: 2400 mm/min.
- ◆ Control Accuracy: \pm 0.5 mm.
- ◆ Case Dimension: 155 \times 87 \times 71 mm.
- ◆ Working Environment Temperature: -10~50 °C.
- ◆ Weight: 1.5 Kg.
- ◆ Detecting System: Capacitance Detector, Arc Voltage Height Detector.

3. Installation

3.1. Mechanical Installation

- ◆ For the names and positions of related components of THC, please see Fig. 3-1.
- ◆ Among the components, the adaptor of capacitive sensor is equipped for flame cutting only.

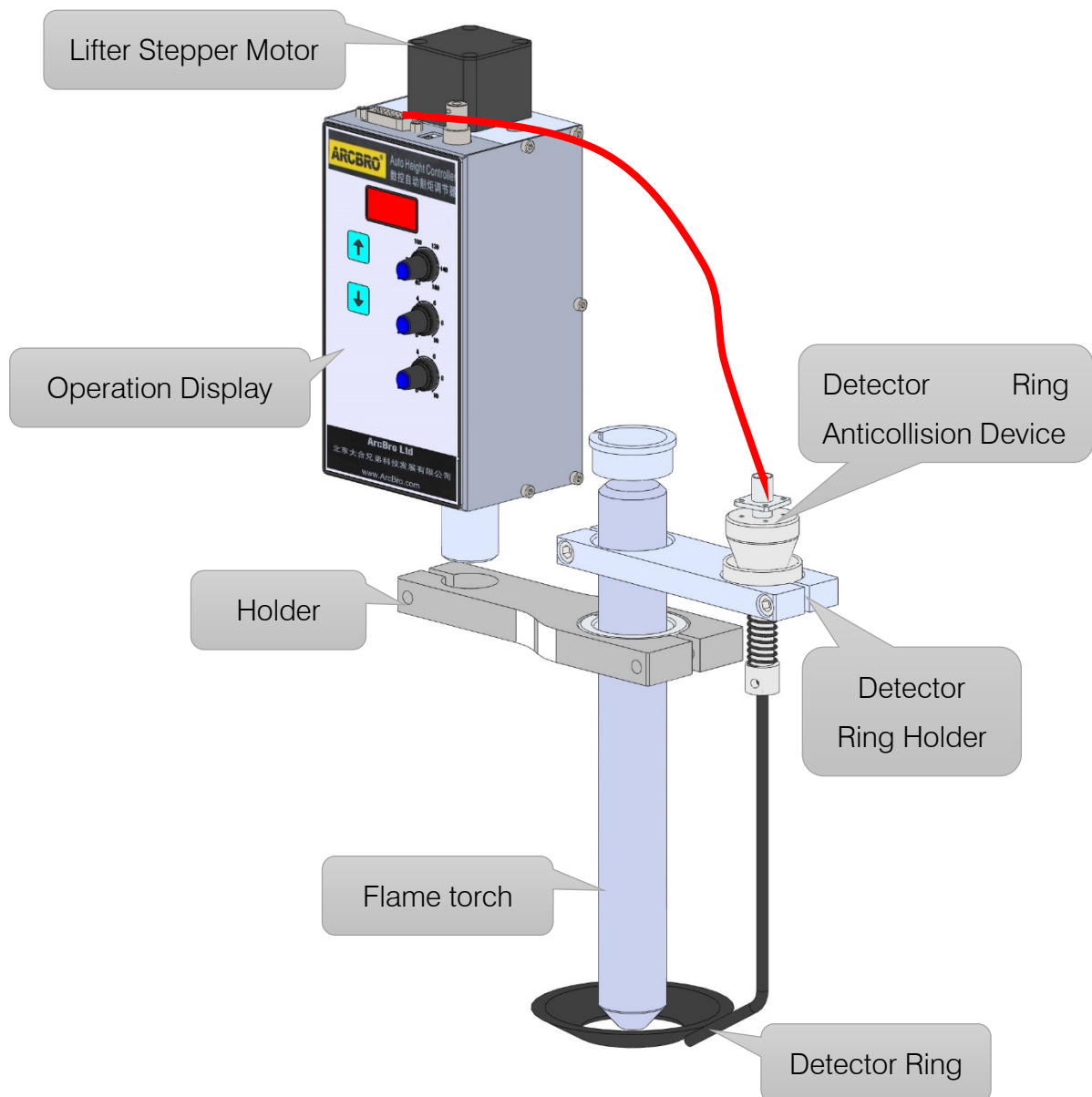

Fig. 3-1 Each Component Position, Name and Function of Controller

- ◆ The 6 pieces of M6 screw holes at back of THC are used to fix the closure to frame. The positions and dimensions of them are shown in Fig. 3-2.

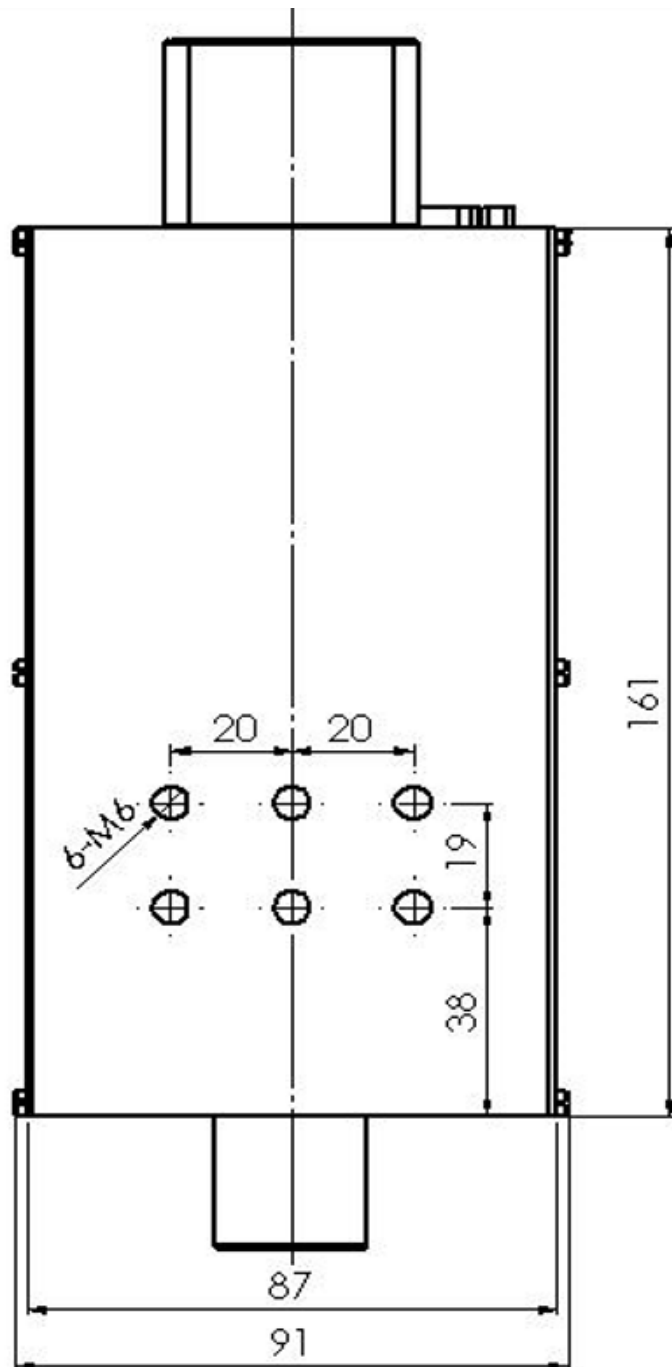
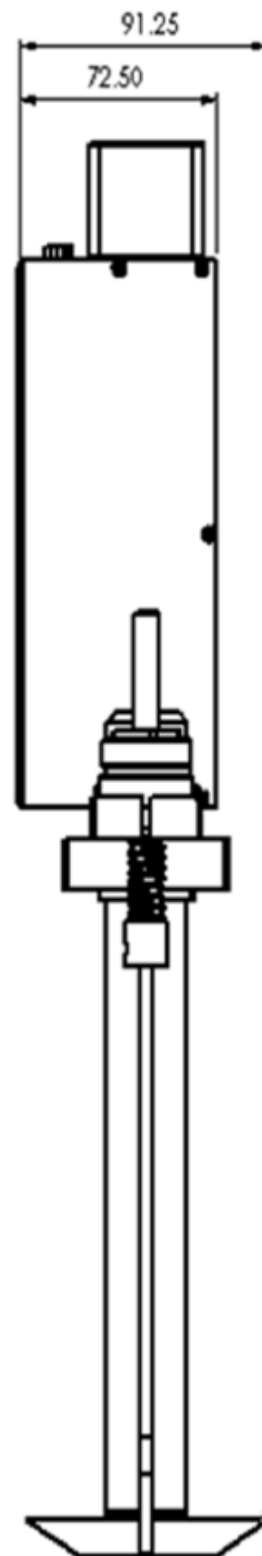
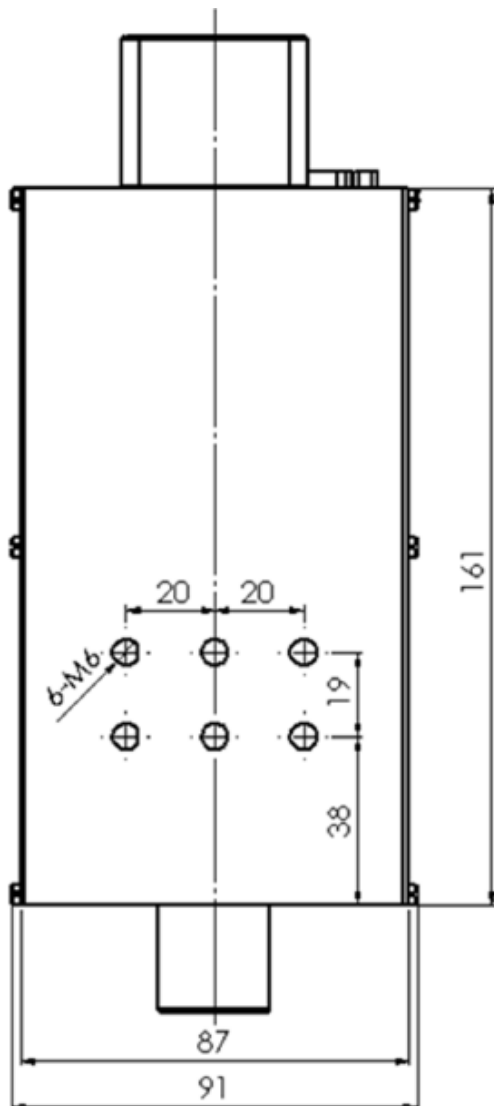

Fig. 3-2 Positions of Installation Screw Holes at Back of Controller

Service Support Spirit

- ◆ For left installation view and related dimensions of THC.
- ◆ For back installation view and related dimensions of THC.



- ◆ For installation sketch of height-controller connecting pieces, please view Fig. 3-5

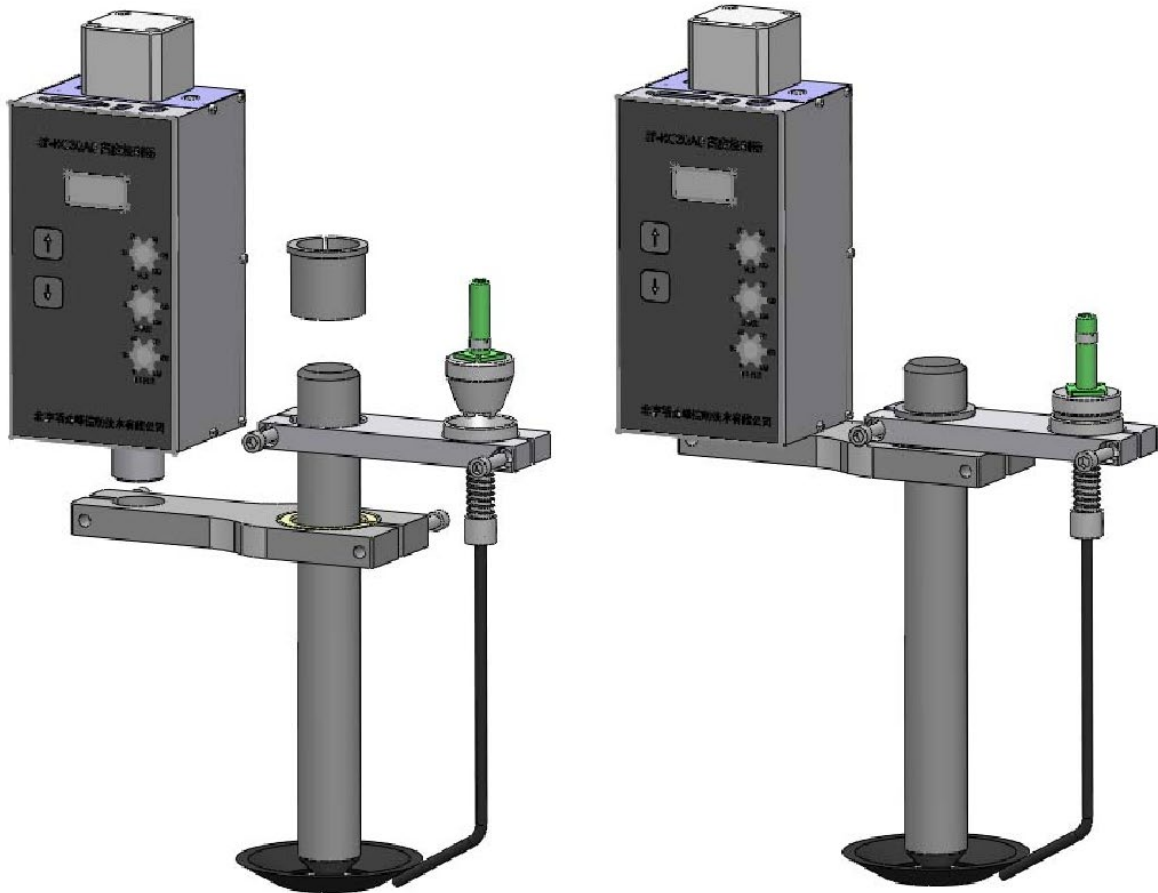

Fig. 3-5 Installation Sketch of Controller Connecting Pieces

3.2. Electrical Installation & Connection

3.2.1 Control Modes of External Switches

The control modes of external switches are applicable for capacitance and arc-voltage height adjustments.

Service Support Spirit

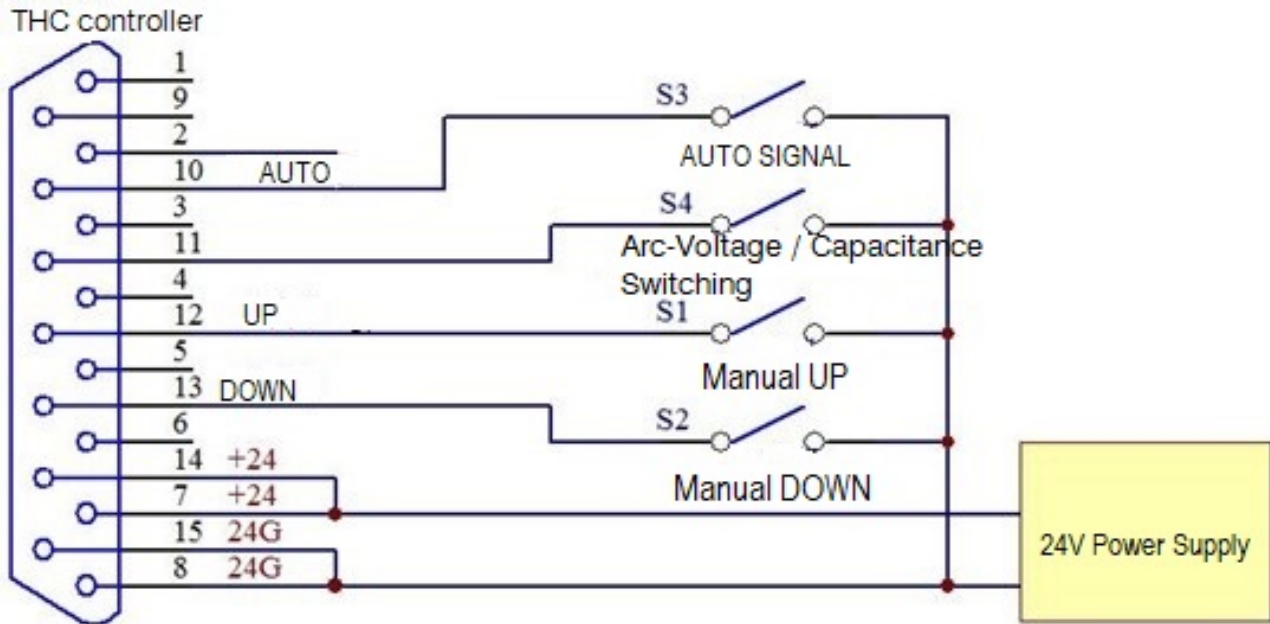

Circuit Diagram of External Switch Control

- ◆ When the S3 is closed, the THC enters automatic mode; when the S3 is open, the THC enters manual mode.
- ◆ When the S4 is closed, the THC enters capacitance mode; when the S4 is open, the THC enters arc-voltage mode (the capacitance mode should be customized).
- ◆ When the S1 is closed, the THC can rise with set speed.
- ◆ When the S2 is closed, the THC can fall with set speed.

3.2.2 Electrical Installation of THC with Capacitance Detecting Mode

- For the electrical installation diagram of such controller, please view Fig. 3-6.
- The high-frequency (HF) cable and connectors are special fittings; the HF cable can be provided 1000 mm according to various requirements.

Service Support Spirit

- The connectors which connect THC (15-Core connector) with Numeric Control System (25-core connector) are prepared by users. The Fig. 3-7 shows the connection; the detailed definitions of 15-core connector and 25-core connector are provided in Table 3-1 and Table 3-2.

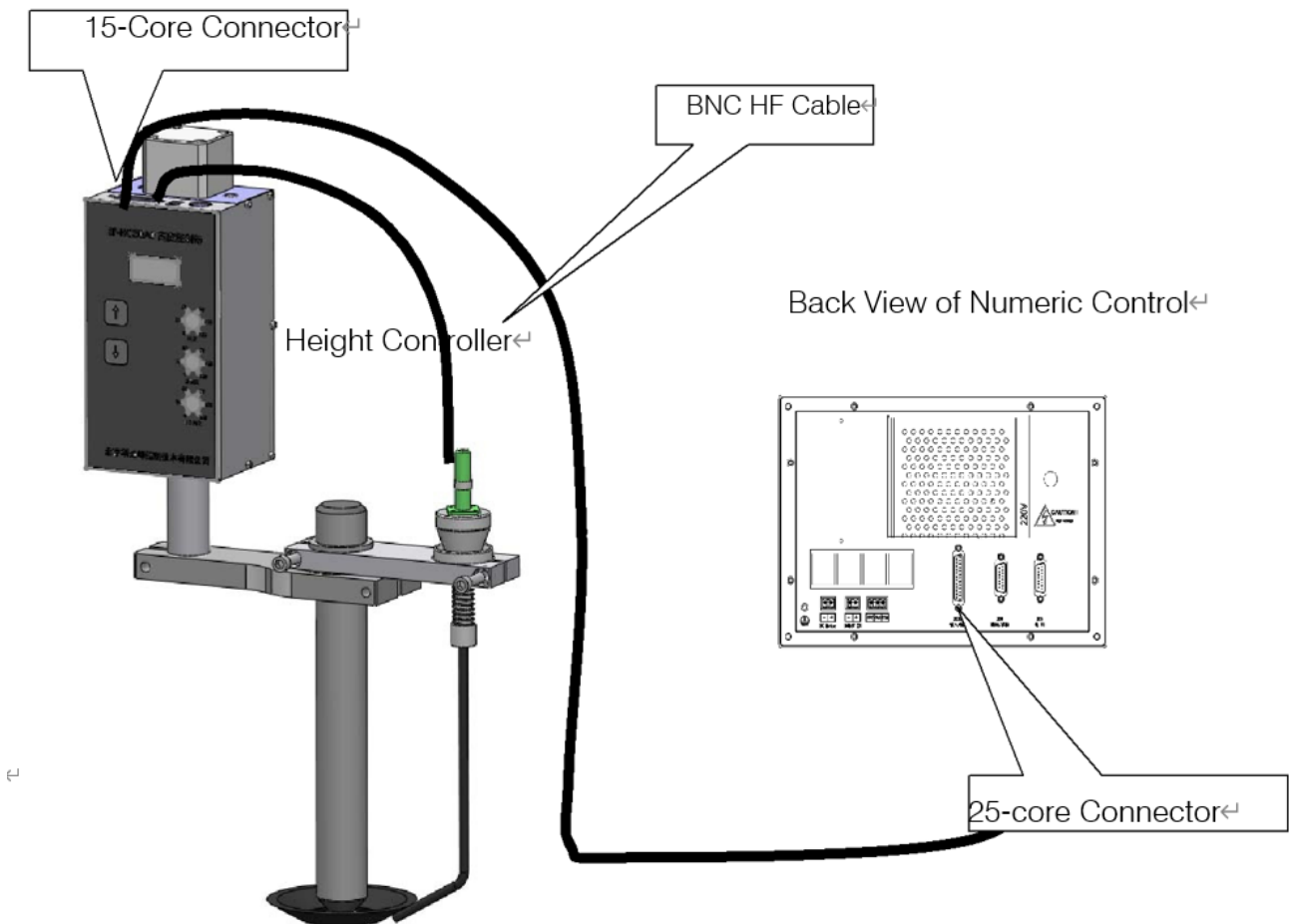

Note: The cross-sections of 24V power-supply cable and ground cable should be over 0.75 mm².

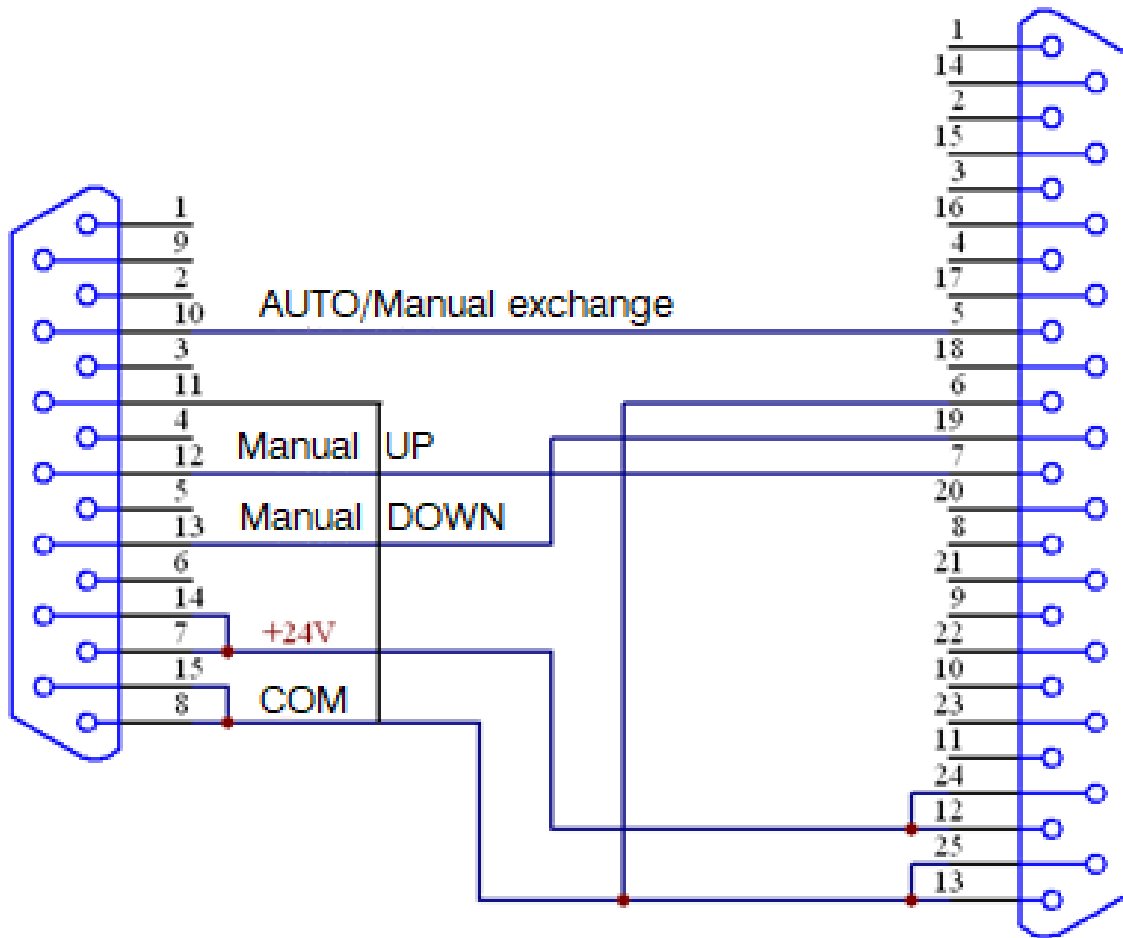

Fig. 3-7 Diagram of Capacitance THC Connecting to Numeric Control System.

Table 3-1 Pin Definition of 25-core Connector:

| NO. | Usage | Description |
|-------|--------------|--|
| 5 | Output | Manual / Automatic Selection Signal |
| 6 | Power Supply | 24V ground, supply power to THC |
| 7 | Output | Manual rising signal, drive cutting torch to rise |
| 12,24 | Power Supply | 24V +, supply power to THC |
| 19 | Output | Manual falling signal, drive cutting torch to fall |
| 13,25 | Power Supply | 24V -, supply power to THC |

Service Support Spirit

Note: the Numeric Control System 25-core connector without pin numbers can not be used.

Table 3-2 Pin Definition of 15-core Connector:

| NO. | Usage | Description | ReMarks |
|------|--------------|--|--|
| 4 | Input | Arc-voltage (cutting nozzle height) signal | |
| 5 | | | |
| 7,14 | Output | 24V +, supply power to THC | |
| 8,15 | Power Supply | 24V -, supply power to THC | |
| 10 | Input | Manual / Automatic Selection Signal | The upper is manual; The lower is automatic. |
| 11 | Input | Plasma / Flame Selection Signal | The upper is plasma; the lower is flame. |
| 12 | Input | Manual rising signal, drive cutting torch to rise | |
| 13 | Input | Manual falling signal, drive cutting torch to fall | |

Note: the THC 15-core connector without pin numbers can not be used.

Service Support Spirit

3.2.3 Electrical Installation of Arc-voltage THC

- ◆ For the electrical installation of arc-voltage THC, please view Fig. 3-8.
- ◆ The cables for connecting THC (15-core connector), Numeric Control System (25-core connector) and voltage-dividing plate (9-core connector) are prepared by user; for the pin definition of 15-core, 25-core and 9-core connectors, please refer to Table 3-4, Table 3-5 and Table 3-6.

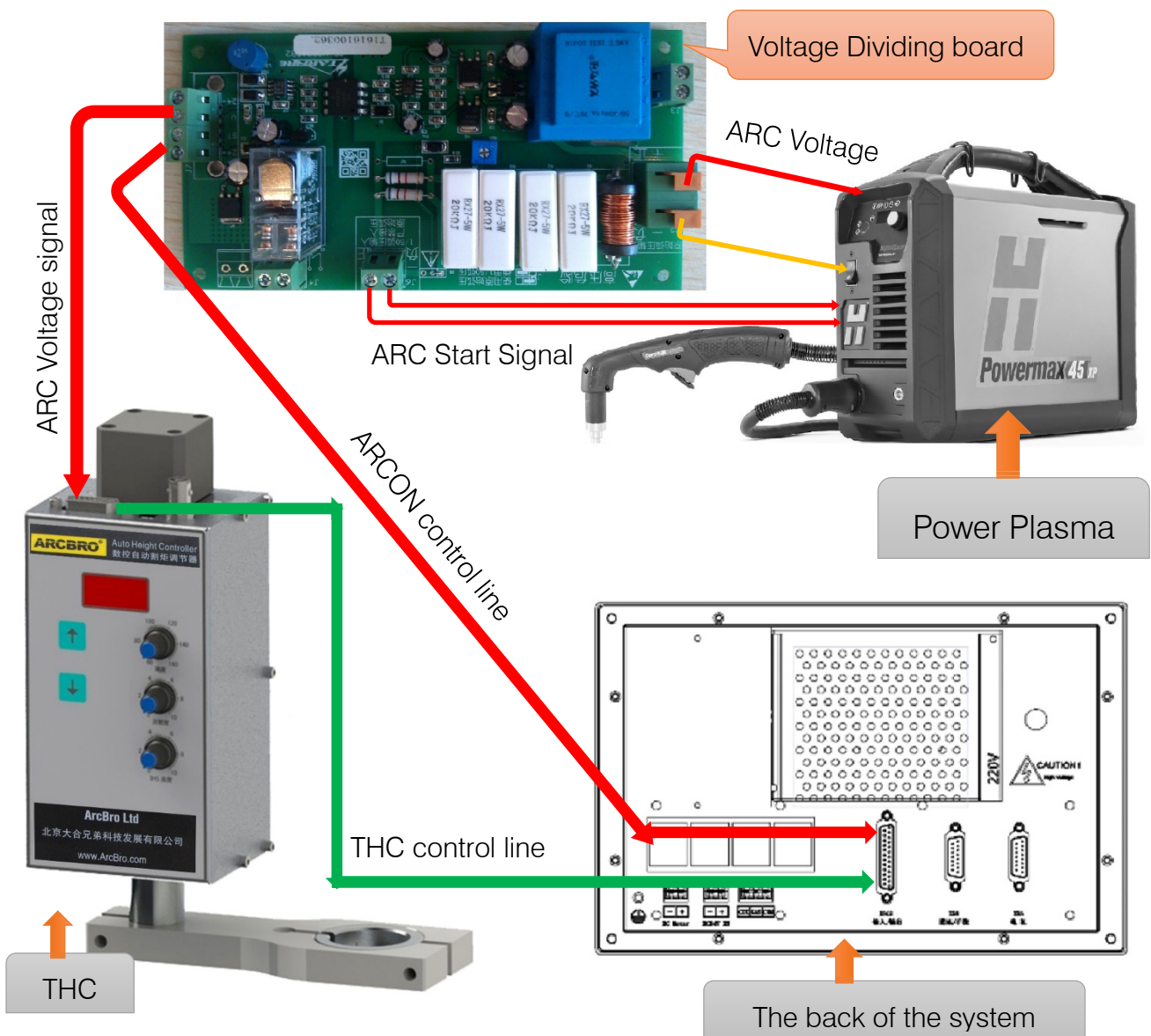

Fig. 3-8 Electrical Installation of Arc-voltage Controller

Table 3-3 Pin Definition of 9-core Connector of Voltage Dividing Plate.

Service Support Spirit

| NO. | Usage | Description |
|-----|--------------|--|
| 2 | Power Supply | 24V ground, supply power to THC |
| 5 | Power Supply | 24V ground, supply power to THC |
| 6 | Output | Arc-voltage Signal, Signal of Plasma Cutting-nozzle Height |
| 9 | Power Supply | 24V +, supply power to THC |

Note: The connector without pin numbers can not be used.

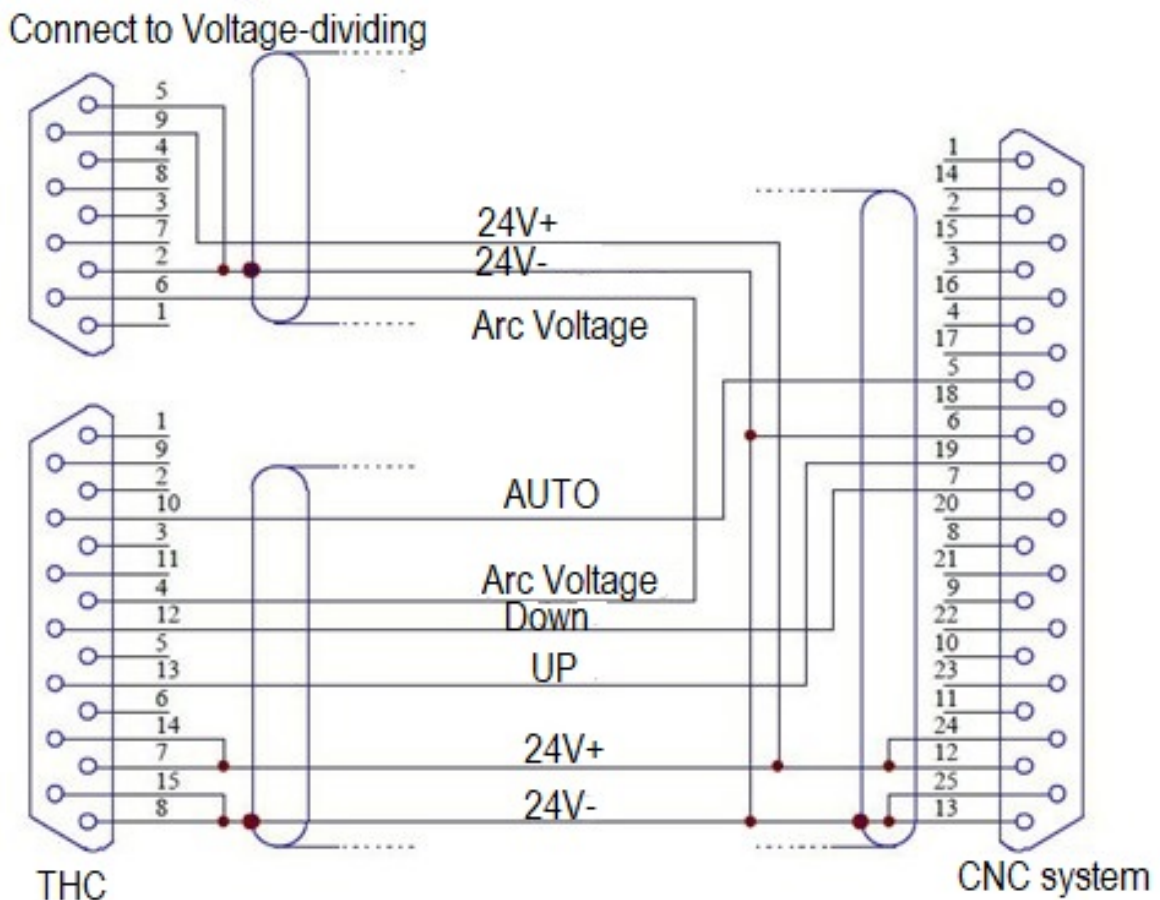

Service Support Spirit

Fig. 3-9 Connection Diagram of Arc-voltage THC, Voltage 25-core Connector of Dividing Plate and Numeric Control System.

Note: the sections of 24V power cable and ground cable should be larger than 0.5 mm².

Electrical Installation of THC with combination of Arc-voltage Detection and Capacitance Detection

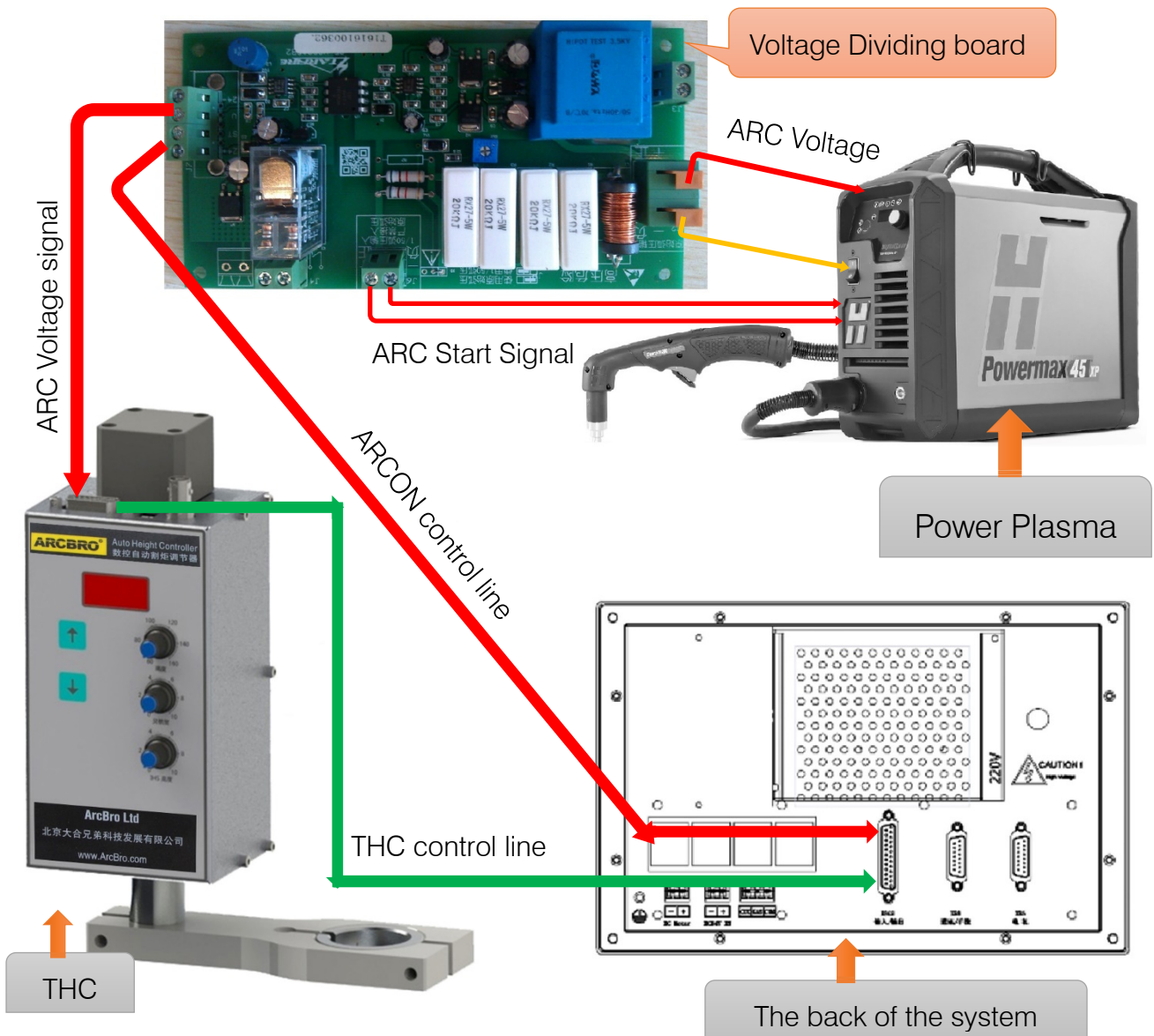
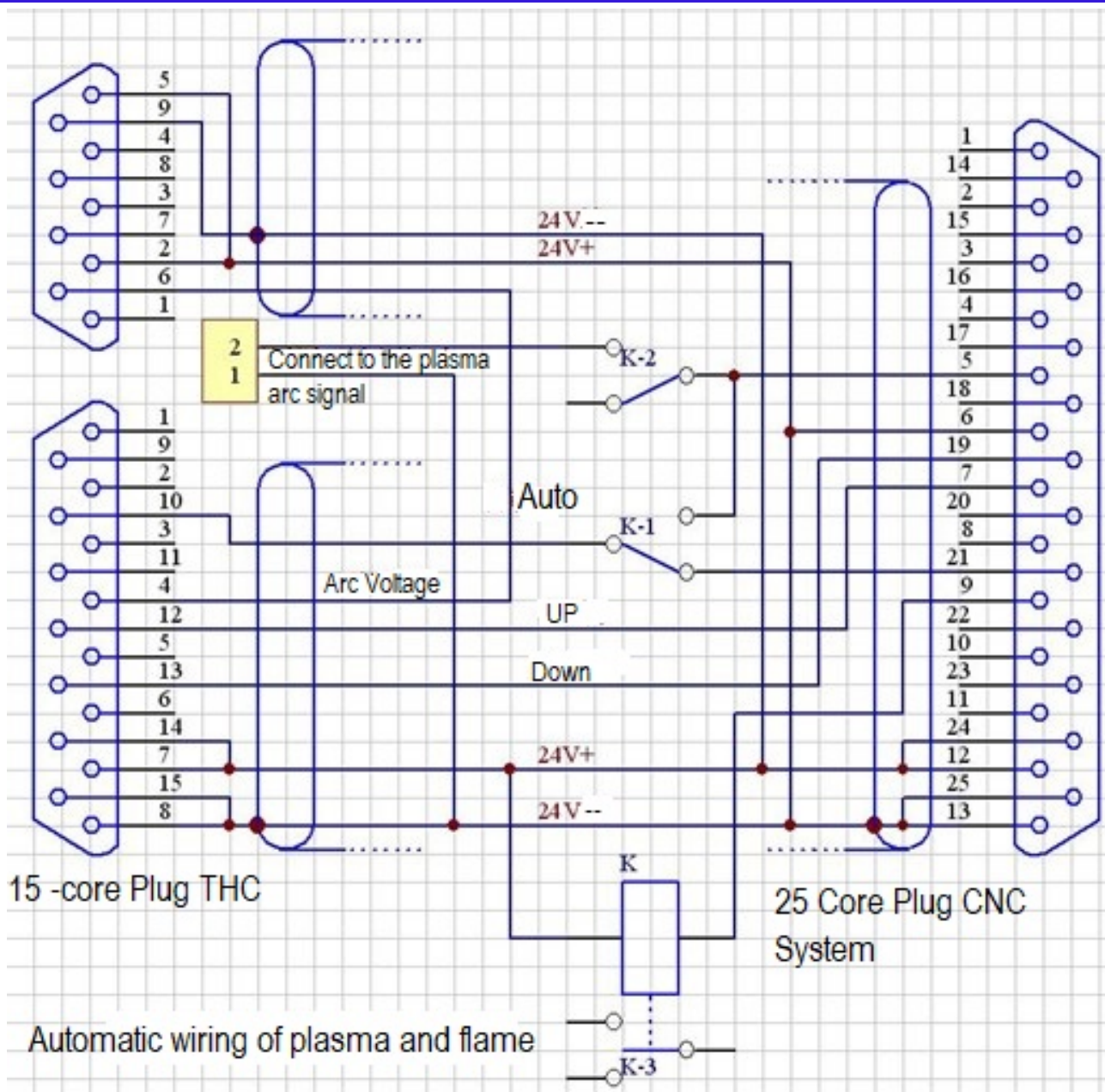

Fig. Electrical Installation of Arc-voltage Controller



Electrical installation diagram of plasma mode

3.3. Function Description of Voltage Dividing Plate

- ◆ The voltage-dividing plate is a function block which proportionally reduces the voltage after making arc of plasma cutting torch, then transform the voltage into a low-voltage signal reflecting the height between cutting nozzle and material plate, and it is necessary fitting for height control in plasma

Service Support Spirit

cutting. The voltage dividing scale of standard voltage-dividing pale of the product is 50:1.

- ◆ The description of each interface of voltage dividing plate is shown in Fig. 3-10.

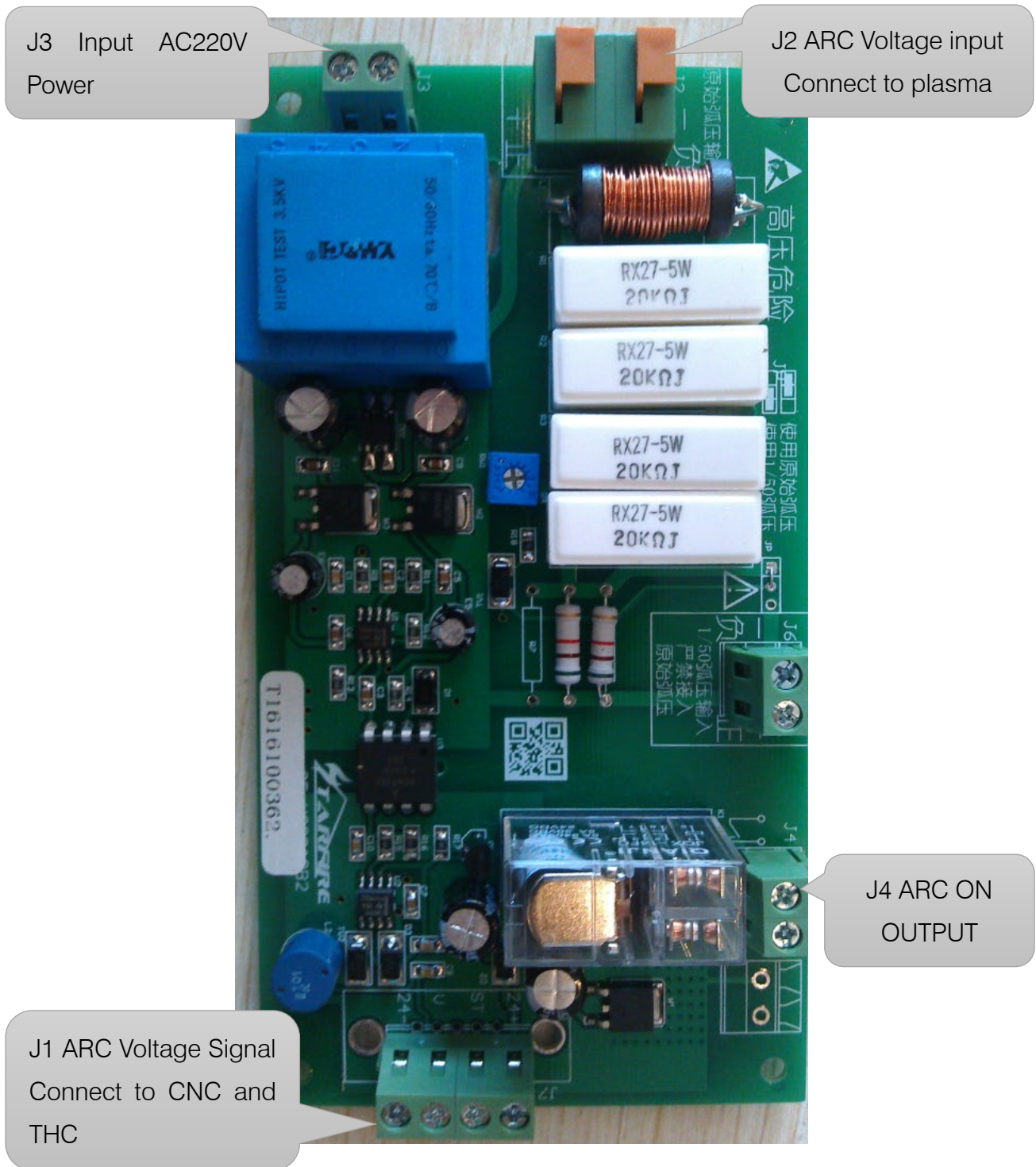

Fig. 3-10 Interface Description of Voltage Dividing Plate

Service Support Spirit

- ◆ For the definition of each pin, refer to Table 3-4, 3-5 and 3-6.

Table 3-4 Pin Definition of J1 Connector:

| NO. | Usage | Description |
|-----|--------------|---|
| 2 | Power Supply | 24V ground, supply power to THC |
| 5 | Power Supply | 24V ground, supply power to THC |
| 6 | Output | Arc-voltage Signal, Signal of Plasma -nozzle Height |
| 9 | Power Supply | 24V +, supply power to THC |

Note: the connector without pin numbers can not be used.

Table 3-5 Pin Definition of J2 Connector:

| NO. | Usage | Description |
|-----|--------------|---------------------------------|
| 1 | Power Supply | Grounding |
| 2 | Input | Plasma Arc Voltage Terminal (+) |
| 3 | Input | Plasma Arc Voltage Terminal (-) |

Note: push the orange button, and insert the peeled cable into connection hole and release.

Table 3-6 Pin Definition of J3 Connector:

| NO. | Usage | Description |
|-----|--------------|-------------|
| 1 | Power Supply | ~220V±10% |
| 2 | Power Supply | ~220V±10% |

- ◆ The installation position of voltage dividing plate can be selected as necessary, but pay attention: J1 interface is used for low voltage signal, and J2 interface is used for high voltage signal. To avoid the HV & HF signal interfere with low voltage signal and improve system stability, the circuits of J1 and J2 should be separated.

4. Process

4.1 Operation process

Process Start

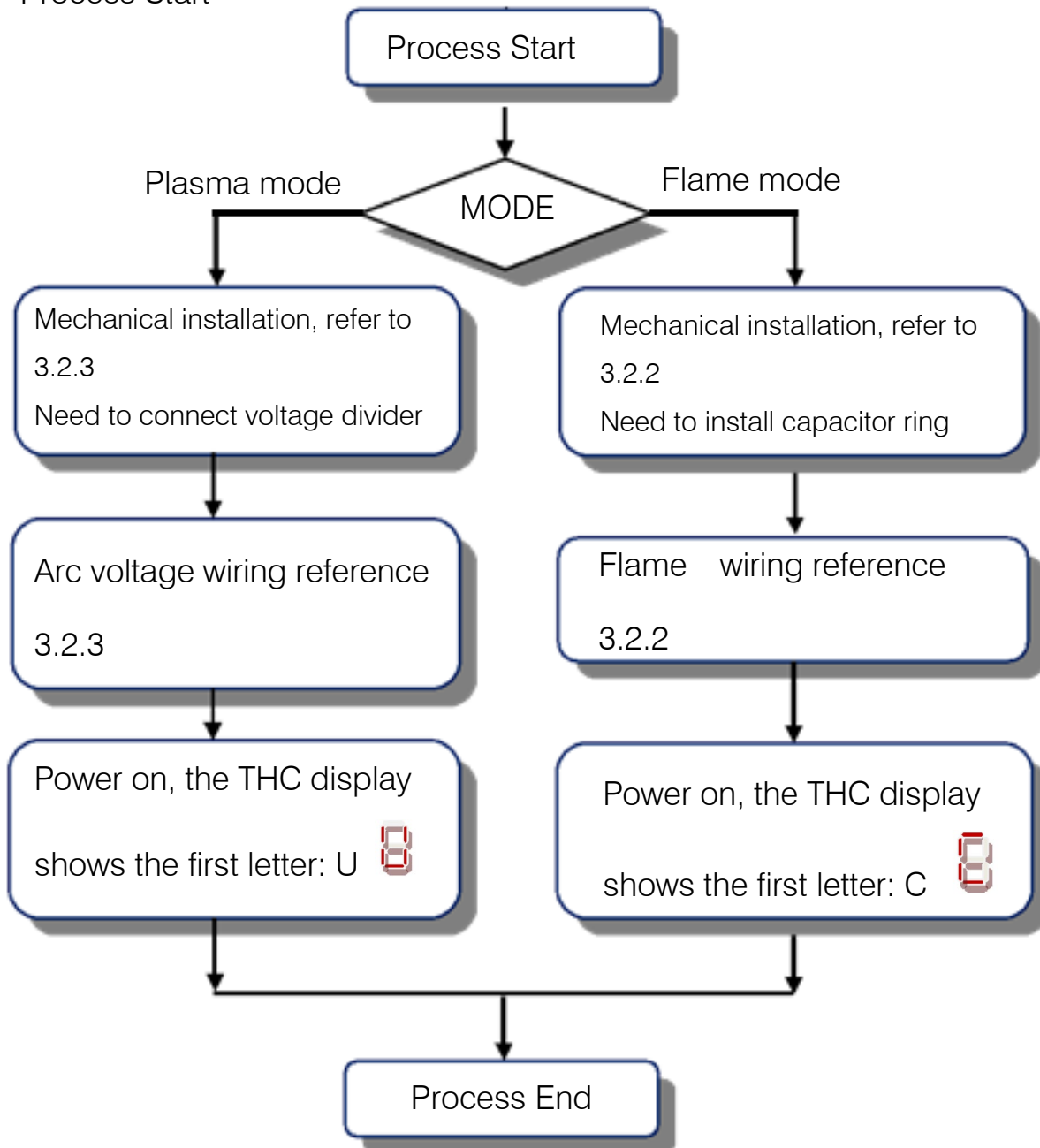

4.2. Work operation process

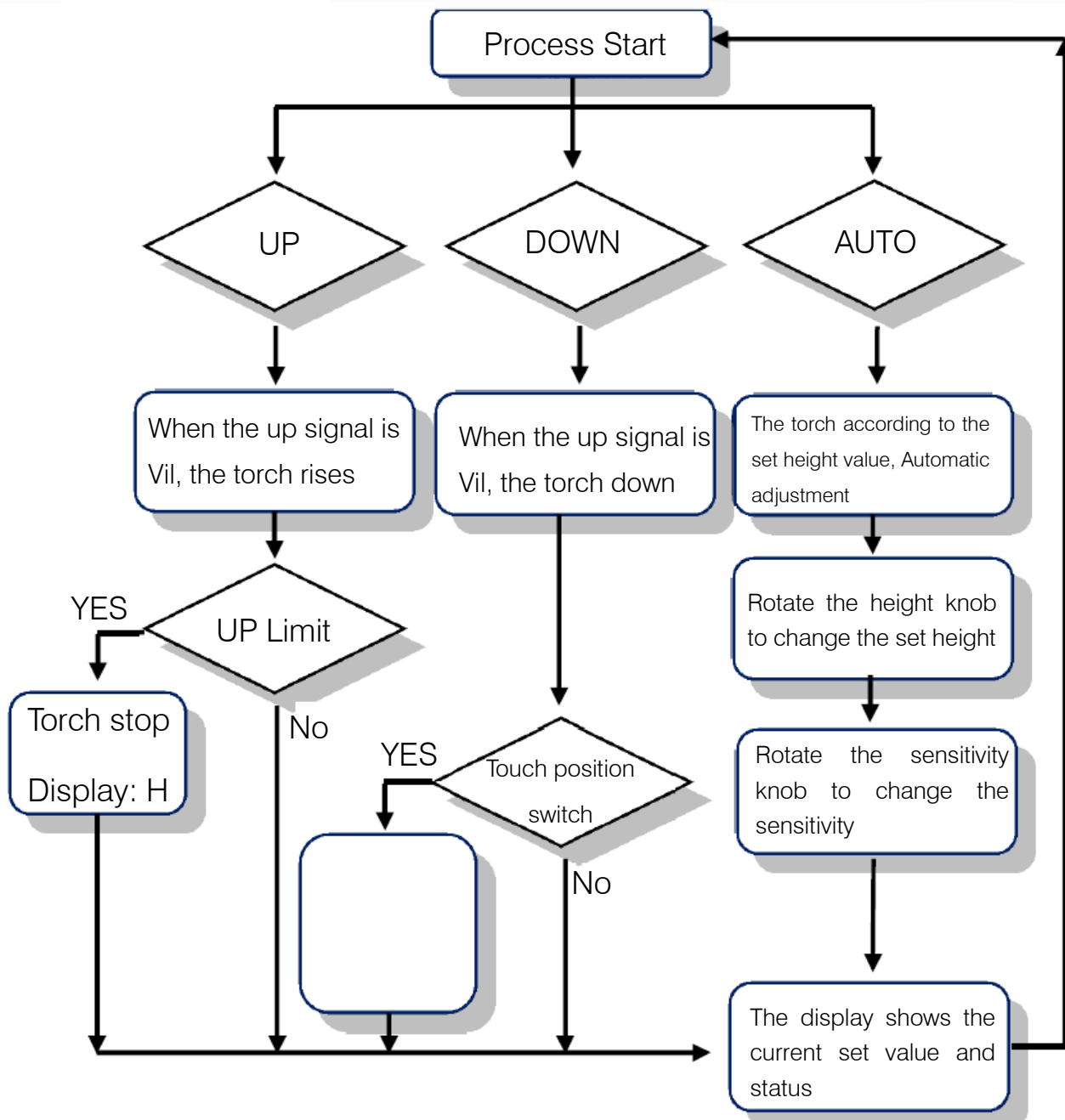

5. Application Guide

After the height controller is started up, there are two states: manual and automatic modes.

5.1. Manual Operation

- ◆ Mode Switching Signal: high voltage, arc-voltage mode; low voltage, capacitance mode
- ◆ Manual/Automatic Signal: when it is high voltage, the controller is in manual mode
- ◆ Manual Up Signal: high voltage, invalid; low voltage, cutting-torch moves upwards
- ◆ Manual Down Signal: high voltage, invalid; low voltage, cutting-torch moves downwards

5.2. Automatic Operation

- Manual/Automatic Signal: when it is low voltage, the controller is in automatic mode.
- In automatic mode, the controller automatically the height of cutting torch according to defined height by user.
- Rotate “Height” button clock-wisely, to increase height and enlarge cutting distance; and to reduce the distance in contrast.

Service Support Spirit

- Rotate “Sensitivity” button clock-wisely, to increase height and enlarge the dead band.
- Rotate “ IHS Height” button clock-wisely, to increase “initial positioning” height; and to decrease the height in contrast.

6. Controller Panel

There are the display and buttons on controller panel. With panel operation, the parameters can be changed and the operation state can be monitored.

6.1. Control Setting

- ◆ **Height Value:** it is the expected value between cutting nozzle and steel plate, and set by user. For the setting scope, refer to Table 7-1.
- ◆ **Sensitivity (Dead Band):** When the actual height is smaller than “Height” + “Sensitivity” and larger than “Height” - “Sensitivity”, the height of cutting torch will not be further adjusted. For the setting scope and factory value, refer to Table 7-1.
- ◆ **IHS Height (Initial Height):** it is the lifting distance of height controller when the cutting torch goes downwards and contact the steel plate. For the setting scope, refer to Table 7-1.

Table 7-1 Setting Scopes of Each Button:

| Mode | | Height | Sensitivity | Initial Positioning |
|-------------|-------------------|---------|-------------|---------------------|
| Arc Voltage | Setting Scope (V) | 60~160V | 0-10 | 0~10 |
| Capacitance | Setting Scope | 160~310 | 0~10 | |

Note: In the plasma mode, just counter-clock-wisely rotate the sensitivity button to bottom!

6.2. Operation Panel

For the operation panel, refer to Fig. 7-1.



Fig. 7-1 Operation Panel





Display: the followings are the display functions:

- ◆ Manual Operation State: operation mode, operation state, height (voltage) set value;
- ◆ Automatic Operation State: operation state, and actual height (voltage) value.

Service Support Spirit

6.3. Description of Displayed States

Manual Operation State: The first digit displays the operation mode and manual operation state, and the following three digits display the height (voltage) set value.

- ◆ **First Digit:** when there is no operation, it displays U:  for arc voltage mode (plasma cutting) and C:  for capacitance mode (flame cutting).
It displays for manual up:  and for manual down: .

- ◆ **Last Three Digits:** In arc-voltage mode, it displays 3-digit numbers which are smaller than 160, the numbers represent the set height (voltage) values which can be changed with rotating “Height” button, and the unit is V; in capacitance mode, it displays 3-digit numbers which are larger than 160, the numbers represent the set height (voltage) values which can be changed with rotating “Height” button.

- ◆ **Automatic Operation State:** The first digit displays the current operation state, and the following three digits display the height (voltage) set value.
The following is the detailed description of first digit:

Service Support Spirit



Adjust cutting-torch up.



Adjust cutting-torch down.



The cutting torch is at suitable height, and remains standstill.

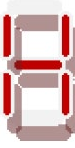

High Limit. When the height is beyond such value, the system alarms. The cutting torch can only move down.



Low Limit. When the height is beyond such value, the system alarms. The cutting torch can only move up.



When the actual arc voltage exceeds the set voltage $\pm 50V$, this state is displayed.

7. Description of Initial Positioning Function

7.1. Positioning Mode

A collision-type positioning switch is equipped inside height controller. When the cutting torch moves downwards and collides with a cutting piece, the internal switch closes; it is unnecessary to equip the special cutting nozzle and “protection cap”, and there should be no electrical circuit between “protection cap” and working piece. Such mode is applicable for all plasma cutting torches.

How to use the positioning function: in plasma mode, the external control interface “manual down” signal is in effect, the cutting torch moves downwards and collides with steel plate, then the internal switch closes, and the internal controller of height controller automatically return upwards a certain distance, that the positioning action is completed.

Note: The moving-down signal delay of numeric control system is about 2 times of moving-up signal delay.

7.2. Setting of Positioning Height

The parameter B is positioning height, and the unit is mm; as there are some over-travel and deformation of working piece and cantilever during the collision test, the B value is usually set to be 5-12 mm. Rotate HIS Height button to set such height value: CW rotate to increase and CCW rotate to decrease.

Note: The above takes our cutting machines as examples.

7.3. Process

The initial positioning function does not demand to add the related processes and commands, just to increase the cutting-torch moving-down time of numeric control system; generally, the cutting-torch moving-down time is 2-6 s longer than moving-up time.

The numeric control system has a cutting-torch moving-up/down action before performing the punching process; the moving-down time is longer than moving-up time, that the cutting-torch can collide with a working piece, then the height controller can detect the collision and return a certain distance to realize the positioning. Note that even now the cutting-torch moving-down signal is not cancelled, the cutting-torch will not move downwards continuously. Wait for the completion of numeric-controlled cutting-torch moving-down delay.

8. Trouble Shooting

8.1 Common faults and how to check.

Table 8-1

| Failures | Inspection Items | Corrective Actions |
|---------------------------|--|--------------------------|
| The motor does not rotate | Is the power supply connected or not? | Connect power supply |
| | Is the supply voltage is correct? | Inspect power supply |
| | Is the motor jammed? | Reduce load |
| No Display | Check power supply | Connect power supply |
| Upper Limit Alarm | The travel is beyond mechanical upper limit. | Check Upper Limit Switch |
| Lower Limit Alarm | The travel is beyond mechanical lower limit. | Check Lower Limit Switch |
| Unstable Signal | Is the grounding of steel plate reliable? | Ground reliably |
| Vertical Oscillation | Sensitivity value too small | Increase sensitivity |
| Accuracy too low | Sensitivity value too large | Decrease sensitivity |