

ARCBRO®

THC-200DC SERIES

Portable Plasma Torch Height Controller

Manual – THC-200DC



THC-200DC



THC-200DC-PT



Operator Manual

ARCBRO | Revision 2 | English

Date of issue: August, 2020

Unique Solution

WWW.ARCBRO.COM

Preview

Thanks for choosing ARCBRO THC.

PTHC is our new generation of AVTHC, with follow new features,

1. Support Torch retaining cap IHS or Nozzle Contact (ohmic contact) IHS with any HF plasma.....Great anti-interference improvement.
2. PTHC has much higher accuracy than old XPTHCs, standard accuracy is 1V, Enough to support HD plasmas.

SAFETY:

- ❖ Please read this manual fully before use PTHC-200DC.
- ❖ DO NOT open cabinet of THC unless trained technician.
- ❖ DO NOT adjust the sealed resister.
- ❖ Turn off Power supply when THC is unused.
- ❖ DO NOT put liquid on THC.
- ❖ Attention Anti-dust work, DO NOT let metal dust into THC.

Installation Note:

- ◆ PTHC-200DC power supply is AC24V or DC24V.
- ◆ GND Must follow THC instruction, GND resister $\leq 1\Omega$.
- ◆ UP/DOWN on THC must be same to Z-axis Lifter.
- ◆ To avoid interference, follow cables please use shield cable (Connection between CNC controller and THC, to motor, to voltage divider, to IHS card), especially the cable from THC to voltage divider, please use shield twisted pair cable, and shield net connected at THC side.

To Customer:

- ❖ We only supply to re-seller as CNC cutting machine manufacturer, engineering company... end-user please contact our local distributor for product supplying.
- ❖ We offer technical support to all distributors and users of our product.

IMPORTANT NOTE:

Service Support Spirit

- ◆ All our THC's have been tested on CNC cutting machine in our workshop before delivery, all commissioning work was done. Please DO NOT change the setting without informing your supplier.

Contents

Preview	2
Contents	4
1. Brief Intro	6
1.1 Product name and model	6
1.2 Specification.....	6
1.3 Basic information	6
1.4 Components	6
1.4.1. Standard package.....	6
1.5 Basic function and features	7
1.6 Installation	8
1.7 Work process	10
1.7.1 Work process with IHS	10
2. PTHC-200DC Function and Setting	11
2.1 PTHC-200DC operation panel.....	11
2.2 PTHC-200DC inside configuration	13
2.3 PTHC-200DC Setting.....	14
2.3.1 Torch lift up after cutting	15
2.3.2 IHS Speed Setting.....	15
2.3.3 THC Sensitive Setting.....	15
2.3.4 Motor Drive Current Setting.....	16
2.3.5 Motor Plug-Braking Setting.....	16

2.4 PTHC-200DC Interface Port.....	16
2.4.1 Power.....	17
2.4.2 Lifter interface (TO TORCH)	17
2.4.3 Interface to CNC controller I/O (TO CNC).....	18
2.4.4 From THC to IHS controller interface : PTHC-IHS (TO IHS)	20
2.4.5 To voltage divider (TO divider)	20
3. Arc-start-voltage-divider and IHS controller	21
3.1 Voltage divide.....	21
3.1.1 None isolation voltage divide	21
3.1.2 Isolation voltage divide.....	22
3.2 PTHC-IHS controller.....	23
3.2.1 PTHC-IHS function	23
3.2.2 PTHC-IHS Interface	23
4. Complete PTHC wiring	26

1. Brief Intro

1.1 Product name and model

Arc voltage Torch height controller PTHC-200DC

1.2 Specification

- ❖ Power supply: AC24V+10%, 50Hz/60Hz 或DC24V, 18V~30V.
- ❖ Support Motor: DC24V motor.
- ❖ Drive mode: PWM.
- ❖ Output current: 1A-4A.
- ❖ Output Watt: 100W.
- ❖ Work temperature: -10~60°C.
- ❖ Initial sense mode: Proximity switch IHS & Torch retaining cap IHS.
- ❖ Voltage divide ratio: 50:1.
- ❖ Accuracy: $\pm 1V \sim \pm 2V$,
- ❖ Lifter speed: 1m/min \sim 4 m/min (over 4m/min, Please contact supplier).
- ❖ Set arc voltage range: 35V~250V.adjustable.

Support Max cutting speed :12000mm/min.

1.3 Basic information

PTHC-200DC is designed to support almost all plasma cutters on market, with full industrial Torch height control functions. It automatically controls plasma cutting height by monitoring the plasma's arc voltage change during cutting.

1.4 Components

PTHC-200DC consists of follow parts.

1.4.1. Standard package

PTHC-200DC standard package includes five parts: (Figure1-1)



PTHC-DIV50

voltage divider

Proximity switch

IHS controller

Retaining cap
cable

- A. PTHC-200DC control module: Installed somewhere easy for operation.
- B. PTHC-DIV50 voltage divider: Inside plasma or CNC cabinet
- C. PTHC-IHS: IHS controller: Installed on Lifter, easy for connection of retaining cap IHS cable and proximity switch.
- D. HV retaining cap cable: Red side installed on retaining cap or nozzle,, black side connected IHS controller.
- E. Proximity switch: mode: HS-C12-N11, NPN , effective distance: 2mm.

1.5 Basic function and features

Auto Initial Height Sensing (IHS), Dual speed IHS
Torch Retaining Cap IHS and Proximity Switch IHS

Service Support Spirit

NPN Proximity Switch IHS is backup for Torch Retaining Cap IHS for cutting dirty/rusty workpiece, needing the Anti-Collision Fixture (Figure 7-1).

Dual speed of IHS

During IHS, THC receives arc start signal from CNC, lift down z-axis lifter for 1 second (adjustable), then change to another much lower speed(1/4 of previous speed) to touch the workpiece for IHS. It effectively raises the precision of IHS and protects torch retaining cap.

Torch Anti-Collision Function

We designed Touch-Up circuit for Anti-Collision Function. No matter it is on Auto Control Model or Manual Control Model, when torch head touches the workpiece, THC would automatically lift torch up to IHS height. This function is mainly made by THC's IHS control circuit,(Ohmic contact IHS and Proximity switch IHS), thus it is effective on both Auto and Manual mode.

Freeze Auto Height Control on Corner Signal

THC's auto height control (auto mode) should only work when plasma's arc voltage is stable(cutting speed is over 90% of full speed). On Arc start/end, corner turning, such speed acceleration/decreasing moment, THC should receives corner signal (Torch height control disable/enable signal) from CNC to free auto mode, to avoid torch diving. PHC-200DC supports all kinds of CNC controllers on market with/without this corner signal.

Lift Torch Up on TURN ON or Arc Off:

When CNC is TURN ON or Plasma Arc Off, THC would lift torch up for 2 seconds, It is adjustable.

Set Pierce Delay Time (Piercing Delay)

Set Button Piercing Delay (set Pierce delay time), delay this output to work as Pierce completed signal, it is a relay switch signal output. THC sends out this signal by monitoring if divided arc voltages get into THC.

1.6 Installation

PTHC-200DC installation as Figure 1.3

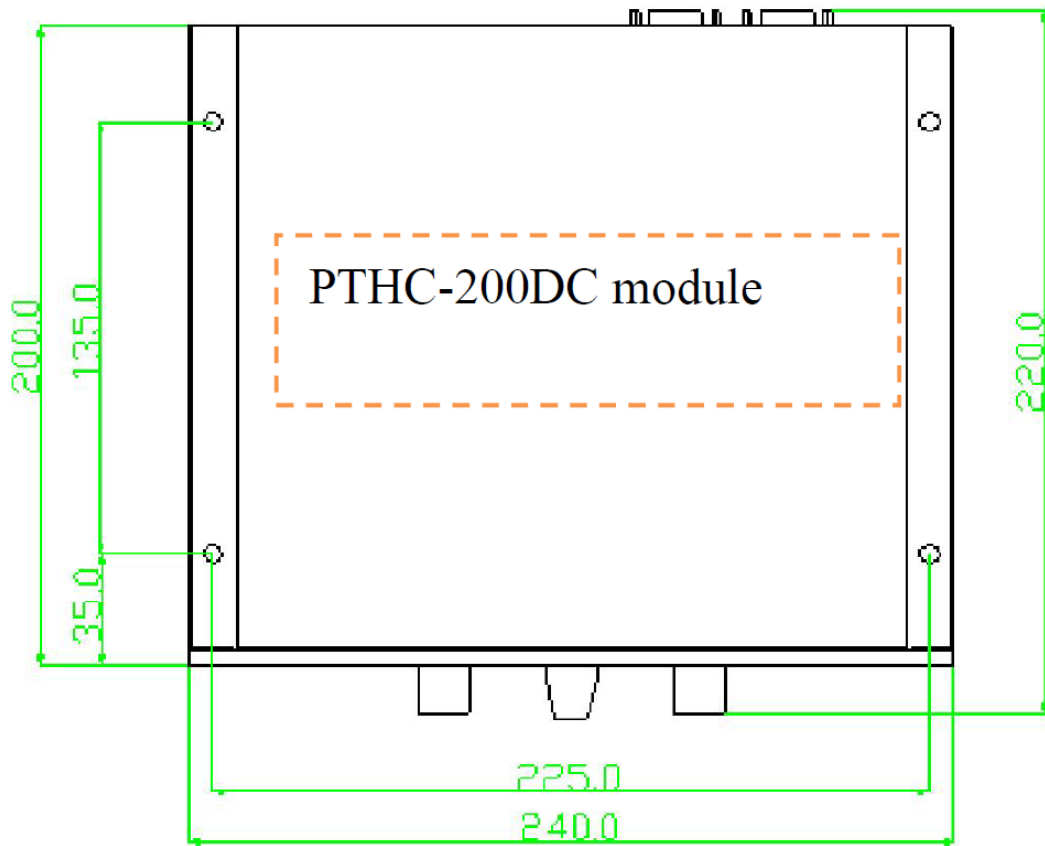
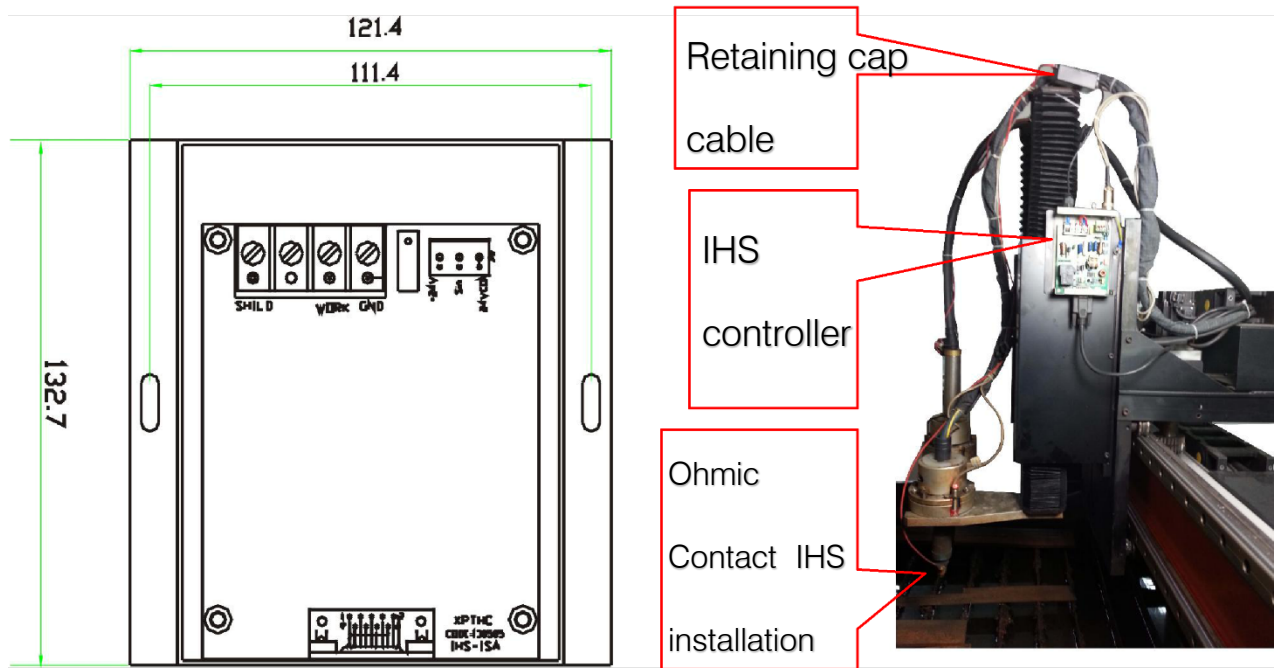

Figure 1-3 PTHC-200DC installation

PTHC-IHS IHS controller installation as Figure 1-4:



1.7 Work process

1.7.1 Work process with IHS

Automatic work flow:

CNC arc start signal to THC---THC start IHS first----Arc start---THC find divided arc voltage in THC-----Pierce time delay----Pierce completed---CNC receives arc ok signal from THC or Plasma then start Motion----over 90% full speed, CNC enable THC's auto mode----Cycle ends and arc off, Torch lift up to programmed height.

2. PTHC-200DC Function and Setting

2.1 PTHC-200DC operation panel

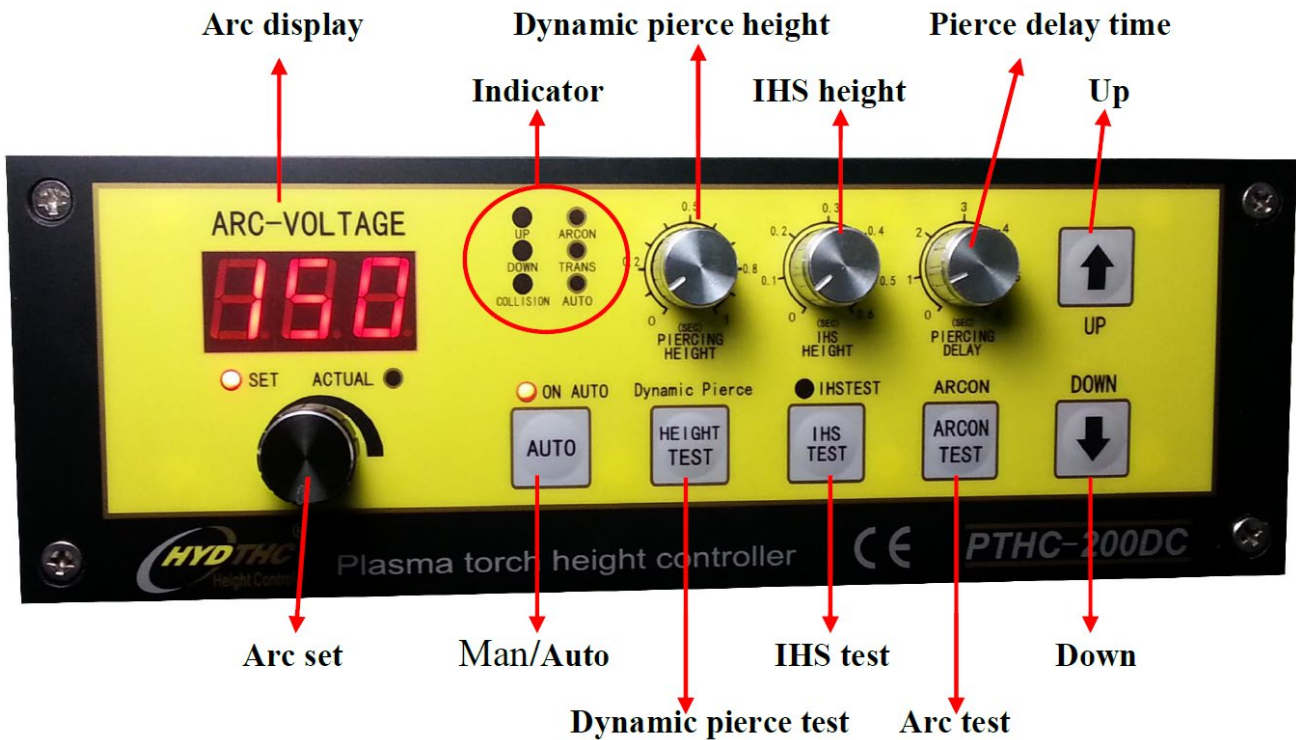

Figure 2-1 Operation panel

Arc Display

Before Arc Start it shows the Set Arc Voltage, after it shows the Actual Arc Voltage.

Set Arc Voltage

Based on the thickness of steel plate being cut and cutting speed, it shall be set according to the parameter offered by Plasma, and it will be showed on operation panel. Set Arc Voltage decides the Torch Height during cut, the higher the arc is, the higher the Torch Height will be. On Auto mode, adjust the Set Voltage means adjusting the Torch Height.

IHS Height

Set Initial Height, turn clockwise, the height increases.

IHS Test

Press one time, it would check IHS one time, which is used to check whether it is a workable IHS or not.

Service Support Spirit

Piercing Delay

Set the Delay Time from Plasma Start to CNC starts cut (delay lead in arc voltage into THC), the Arc feedback (arc ok) signal would be sent to CNC only after arc voltage is detected by THC.

Piercing Height

Set dynamic pierce height, it only works when THC find divided arc volt get into THC, The dynamic pierce start time can be adjusted by Piercing Delay(pierce delay setting). If no need dynamic pierce, please set it at 0(Zero)

Dynamic Pierce Height Test

Press and hold, torch lift up a dynamic pierce height for a test.

Auto

Set THC Auto or Manual mode. Meanwhile enables the Auto Signal between connectors of CNC and THC.

ArcOn Test

Press to test the Plasma Start. During test, Torch lifts up an IHS height.

Up/Down

Manual operation button of Up and Down. It is effective on any mode.

6 LED indicators:

UP/DOWN: Turn on when torch lift up/down,

Collision: Turn on when torch touches workpiece, it can be activated by torch retaining cap or proximity switch both. During IHS, it would flash once.

ARCON: Turn on when THC sends arc start signal out. If arc start with HIS enable, this indicator is off until IHS completed.

TRANS: Turn on when THC finds divided arc get into THC. And sent out Arc OK signal to CNC.

AUTO: Turn on means THC is on Auto Mode, four conditions must be satisfied:

1. CNC Auto Height Control (THC) enables;
2. THC is on Auto Mode (Auto/Man);
3. THC finds divided arc volt (Trans turns on);
4. Actual Arc Voltage not higher than Set Arc Voltage over 30V.

Service Support Spirit

◀ Note:

- A. When THC on Auto Mode, the **5 Silver indicators** all are ON. If anyone is OFF, that means Auto Mode failed, please check the reason according to indicators' on/off state.
- B. There are **6 indicators** on Operation panel, demo THC from Torch down—Touch workpiece—arc start---arc feedback---Auto on, please check. the failure reason from the one-by-one steps.

2.2 PTHC-200DC inside configuration

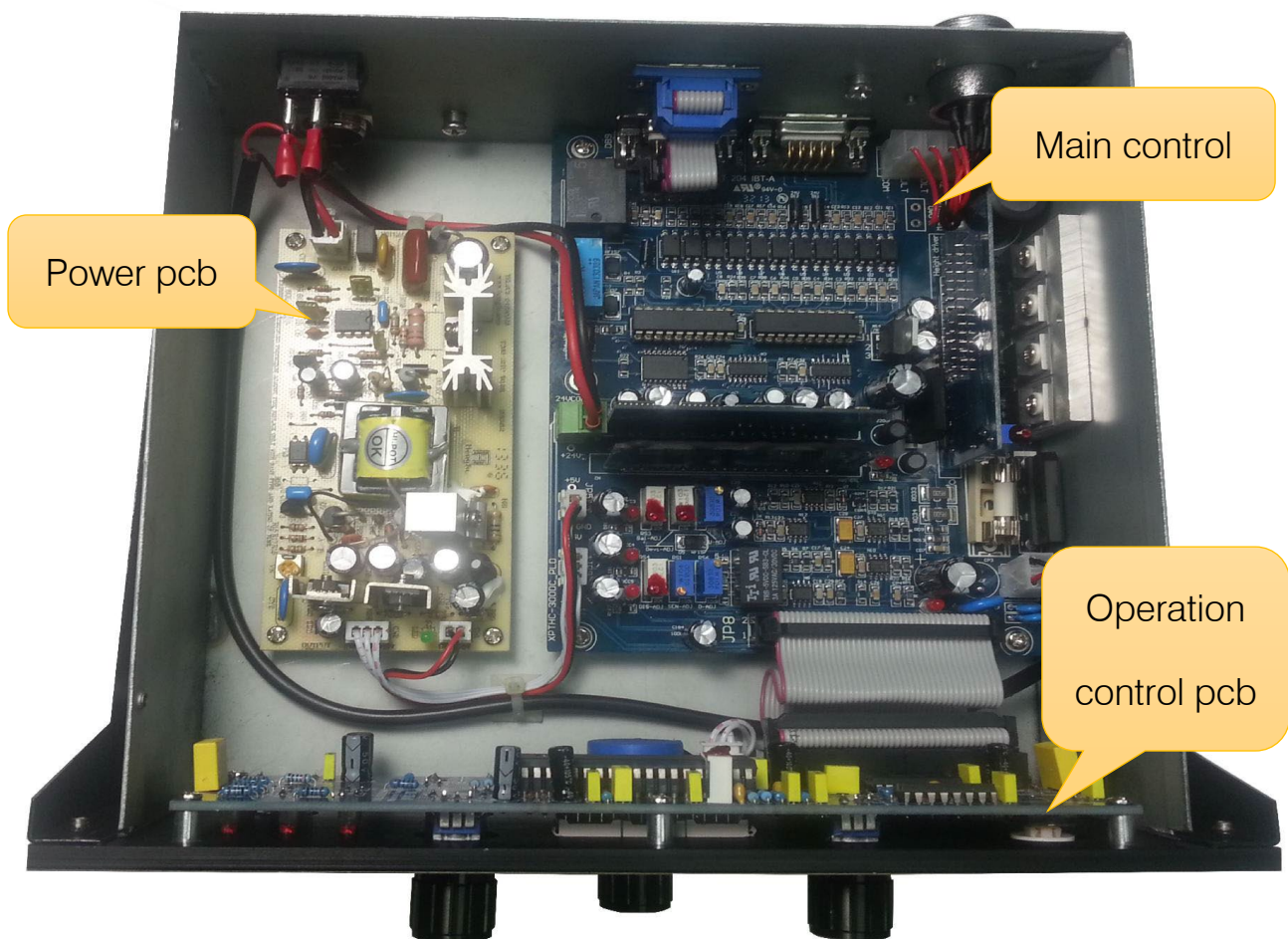
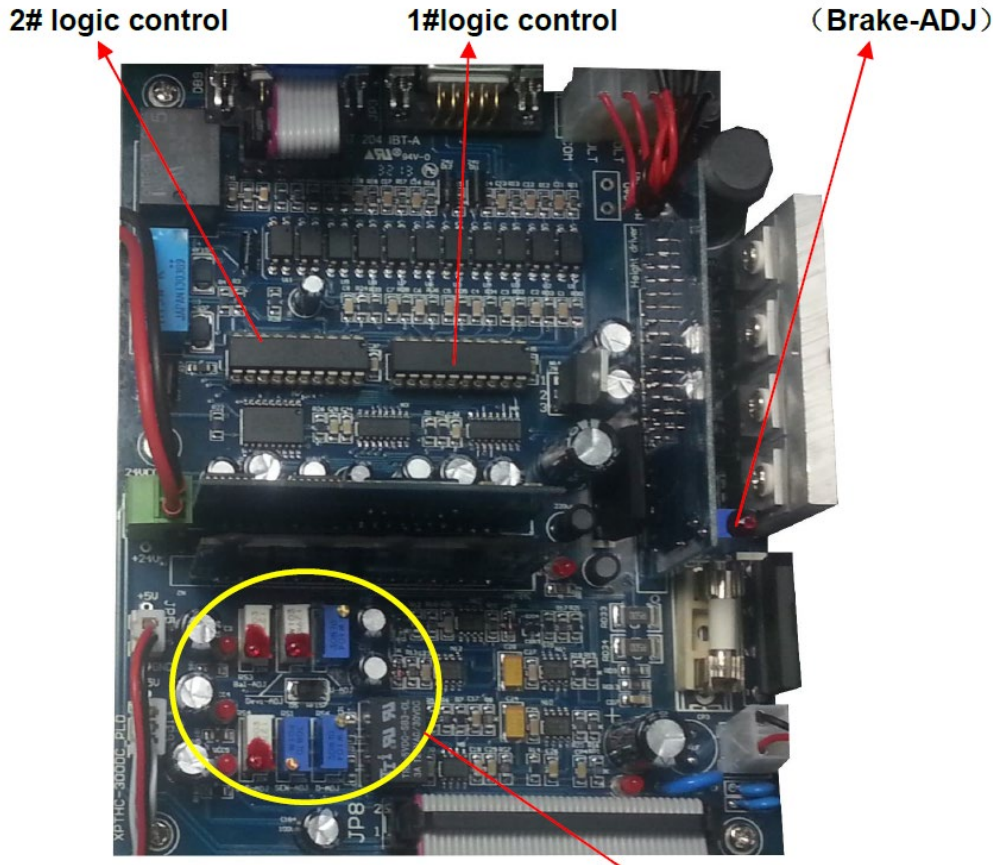

Figure 2-2 PTHC-200DC

Service Support Spirit

2.3 PTHC-200DC Setting

DO NOT ADJUST THE RED SEALED!



- RS3: Balance speed adjust.
 - RS2: Volt divide ratio (50:1) .
 - RS5: Lift up time adjust after cutting.
 - RS6: IHS slow speed stroke adjust.
 - RS1: Sensitivity adjust, already on Max.
 - RS4: display match.
- Note: THC is already commissioned before delivery, please not change the setting without informing supplier.

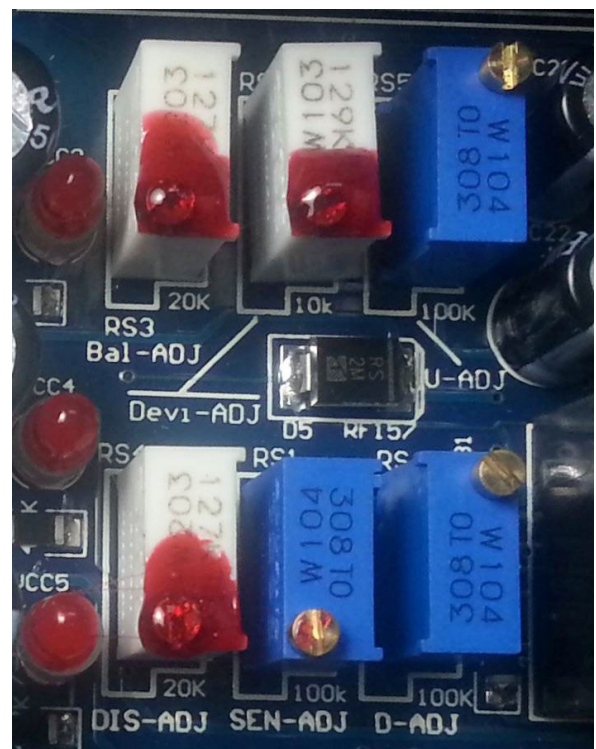

Service Support Spirit

2.3.1 Torch lift up after cutting

PTHC-200DC can adjust the Torch Lift Up Height via setting RS-5 (U -ADJ on PCB, Clockwise increase the height, with range 28 turns.

Before setting, all THC cables must be connected, torch Up/Down function workable, IHS is ok.

Method A:

- A. Close plasma power.
- B. Press button "DOWN" on THC, lift down torch to cutting height properly.
- C. Press button "ARCON TEST" once, at least 0.5 second, torch lift up automatically.
- D. If torch lift up height is ok or not, increase on clockwise, decrease on counter-clockwise.
- E. Repeat A-D steps, until reach a right height.

Method B:

- A. Turn off plasma.
- B. Operation on CNC (plasma mode), CNC control THC to complete IHS and arc start, then ARCON indicator is on.
- C. Pause CNC, cutting signal missed, torch would lift up automatically.
- D. If torch lift up height is ok or not, increase on clockwise, decrease on counter-clockwise.
- E. Repeat A-D steps, until reach a right height.

2.3.2 IHS Speed Setting

It is Dual speed IHS on PTHC-200DC. It can set the fast speed stroke via setting RS6 (D - ADJ on Pcb) , The stroke increases on clockwise turn. This setting should be done after the commissioning of Torch Lift Up after cutting, and without Manually lift torch up/down. RS6 maximum turns 28 round.

2.3.3 THC Sensitive Setting

PTHC-200DC sensitivity is adjustable via setting RS1 (SEN-ADJ on Pcb) . The sensitive of THC decides the cutting accuracy. As the difference of torch lifter design and speed, it needs to adjust the THC sensitive for different lifters. Sensitive increases on clockwise, decrease on

Service Support Spirit

counter-clockwise. RS1 maximum turns 28 Round.

Note: If sensitivity is too high, torch would shake, please test it carefully.

PTHC-200DC is tested on 3000/min lifter, so for 1000mm/min—3000mm/min speed lifter, no need user to commission it.

Sensitivity matters to the quality of lifter. If the lifter can lift torch up/down on with DC motor Power supply below 3V, it is quality lifter for PTHC-200DC.

2.3.4 Motor Drive Current Setting.

This THC's Max output drive current is 4 amps, if your motor is over 4amps,PTHC-200DC cannot support your lifter, please contact us if you need further revising of product.

2.3.5 Motor Plug-Braking Setting.

XPTHC-300 achieves fast braking by Plug-Braking. It can be set via Resister (Brake-ADJ) on PCB Usually no need user's commission.

2.4 PTHC-200DC Interface Port

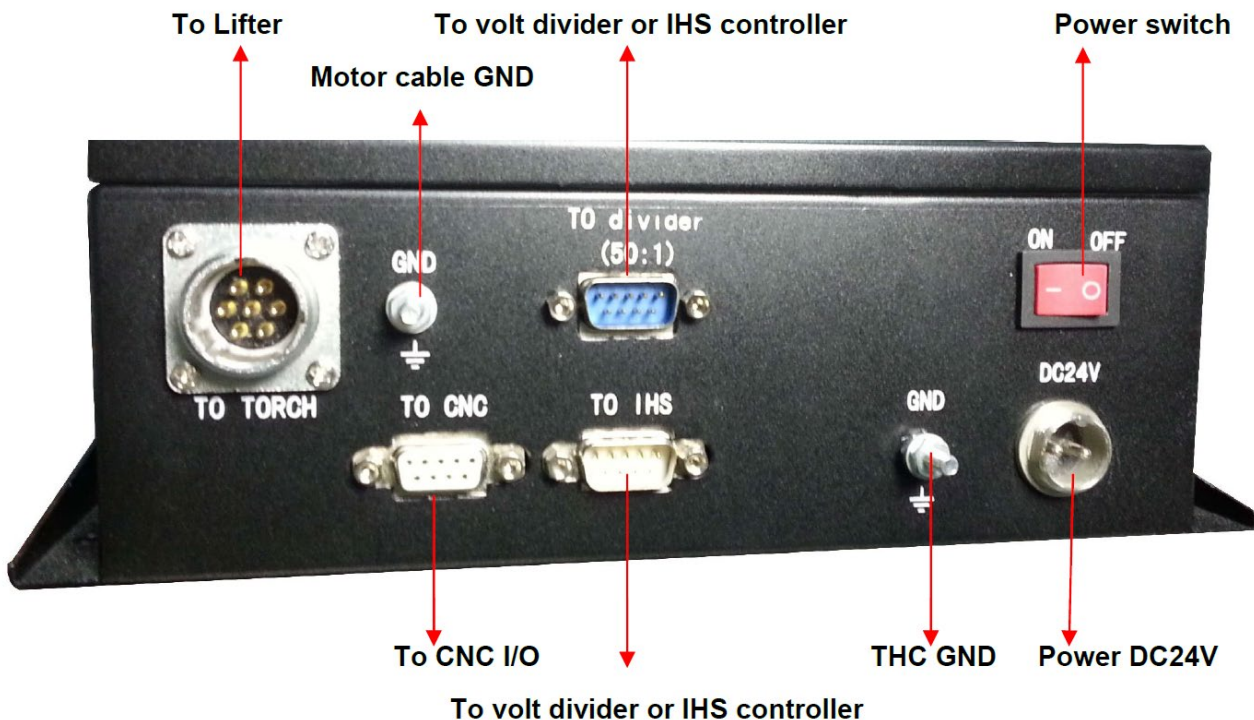

Figure 2- 4 PTHC-200DC

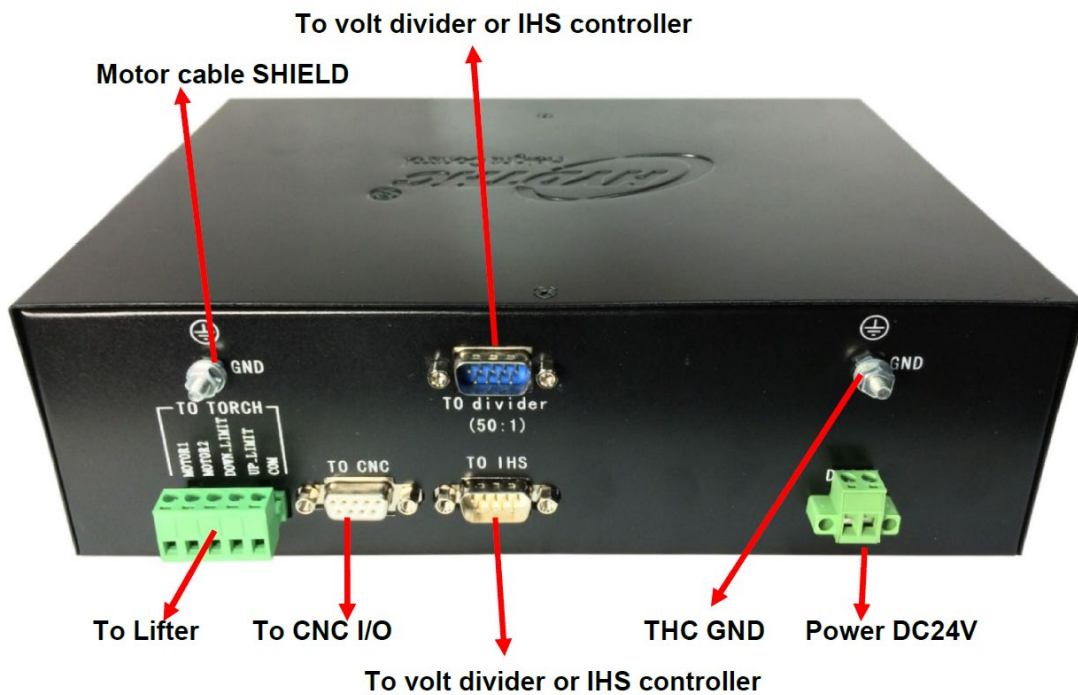

Figure 2- 4 PTHC-200DC-PT

2.4.1 Power

PTHC-200DC supports DC24V and AC24V power supply both, But we suggest DC24V would be better. Connected to THC via $\Phi 16$ socket, as right picture shows,

24V power depends on DC24v motor's watt, formula as follow:

$$\text{Power supply} \geq 2 * \text{Motor Watt} + 25W$$

Please offer separate power supply for THC, and THC cabinet must be grounded.

2.4.2 Lifter interface (TO TORCH)

Torch connector uses 7-pin socket to connect with motor, showed as follow:



Service Support Spirit

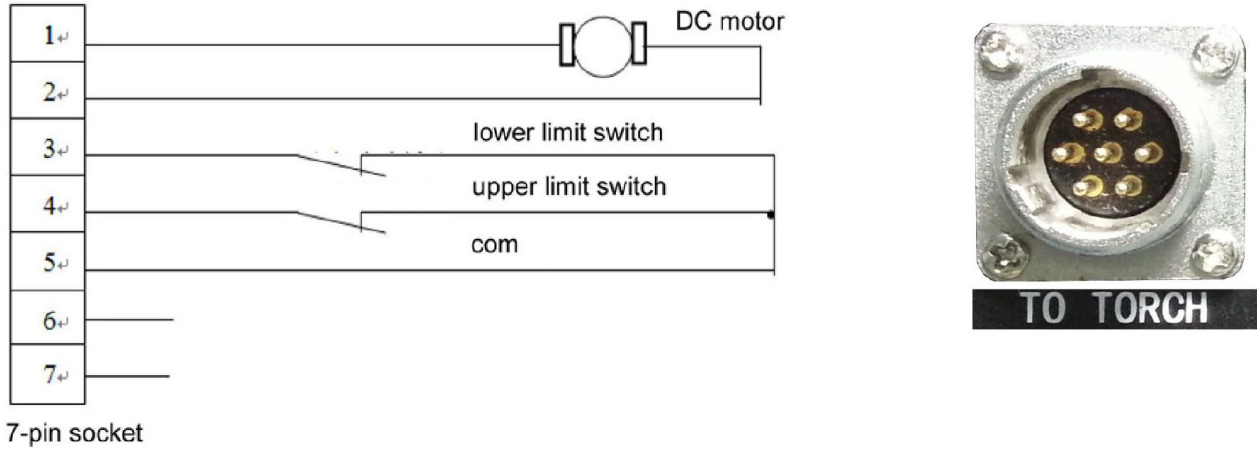

Figure 2-5 TO TORCH

TO TORCH interface:

Pin(s)	Signal	Description
1,2	DC Drive(Output) Motor	DC motor drive output Drive. DC24Vmotor directly. Max 100W PWM
3	Down LIMIT (Input)	Down limit input. Limit switch normally closed. Short connect pin3 and 5 (optical ISOLATED).
4	UP LIMIT (Input)	UP limit input. Limit switch normally closed. Short connect pin4 and 5 (optical ISOLATED).
5	LIMIT COM	COM

2.4.3 Interface to CNC controller I/O (TO CNC)

PTHC-200DC connects to CNC via DB9, as Figure 2-6,

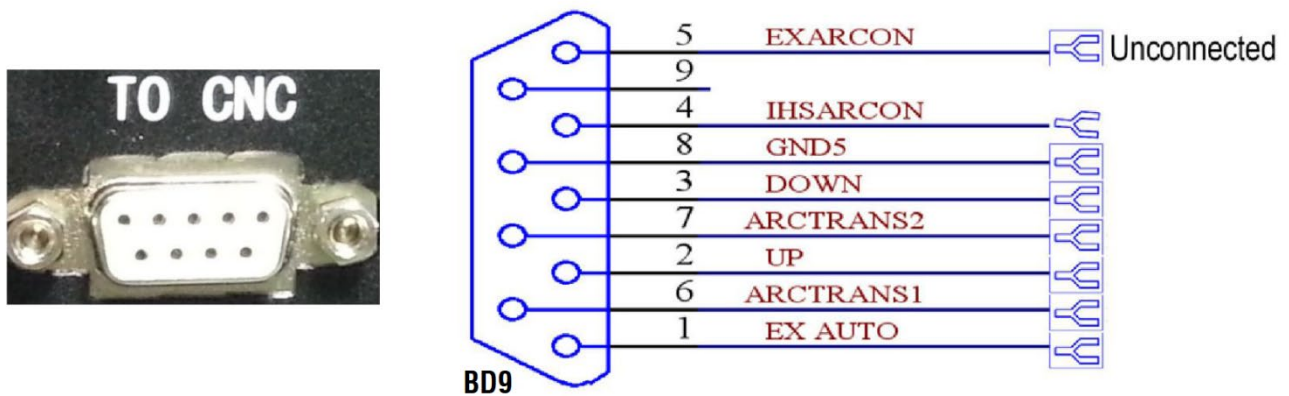

Figure 2-6 PTHC-200DC

Service Support Spirit

Note:

- ❖ All communication with CNC is isolated, original set is Low Level effective.
- ❖ Arc OK signal (ARCTRANS1, ARCTRANS2) is a switch signal.

TO CNC Pin definition as follow:

Pin(s)	Signal	Description
1	AUTO	Auto signal, low-level effective, Controlled by CNC's corner signal or THC enable signal, pin8 is control Com
2	UP	Up signal, low-level effective pin8 is control Com
3	DOWN	Down signal, low-level effective pin8 is control Com
4	ARC ON with IHS	Arc start with IHS, low-level effective pin8 is control Com
5	EX ARC ON	Arc start without IHS, low-level effective pin8 is control Com
6,7	Arc ok signal RELAY OUT	Connect to CNC's arc feedback signal input Relay output
8	Control COM	Isolation control COM
9	Collision output	Optical isolation, OC door output, Max :200mA

Service Support Spirit

2.4.4 From THC to IHS controller interface : PTHC-IHS (TO IHS)

5-pin shield cable: PTHC-IHS-10.

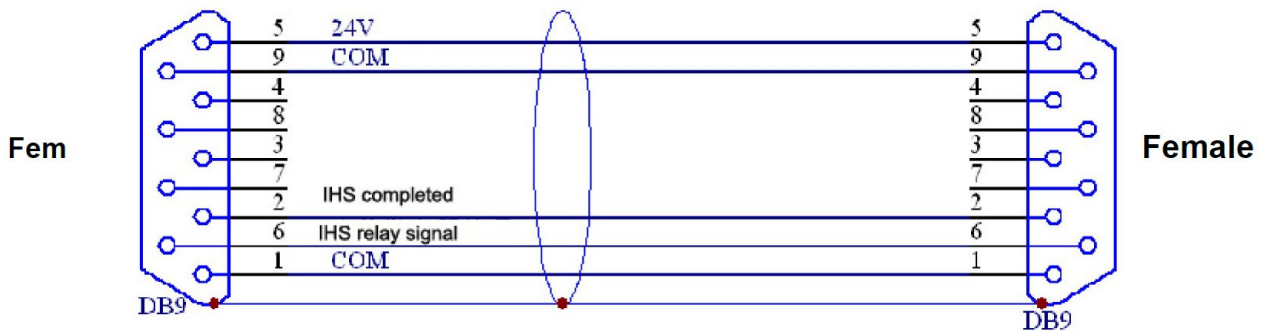
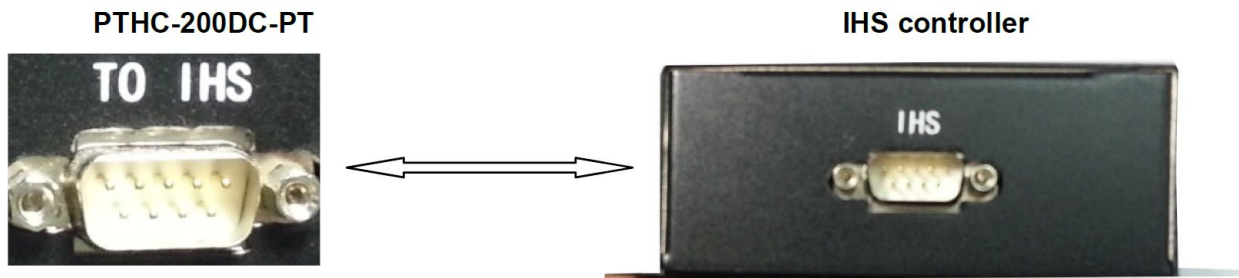
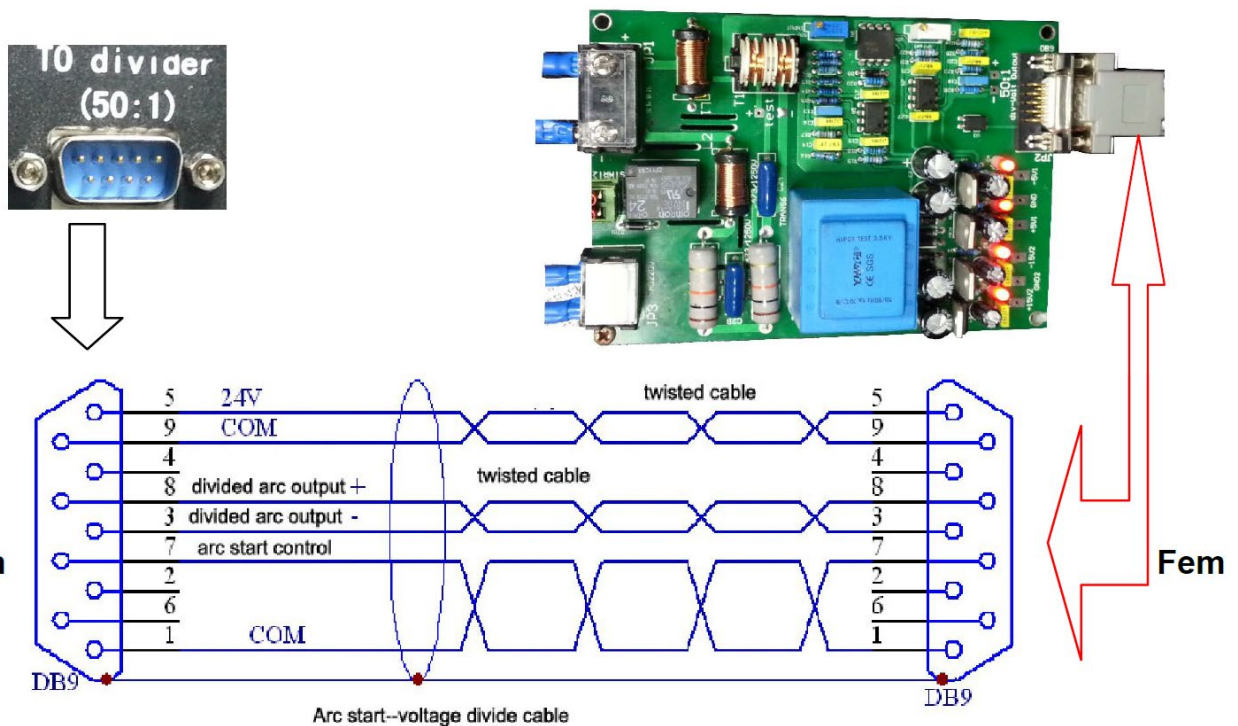

Figure 2-7 PTHC-200DC--PTHC-IHS cable

2.4.5 To voltage divider (TO divider)

Figure 2-8, 6-pin twisted shield cable, PTHC-ARC-5meters.



3. Arc-start-voltage-divider and IHS controller

3.1 Voltage divide

Arc voltage THC must monitor the plasma's arc voltage change. The plasma's arc voltage is same as the volt between Electrode and Earth.

Plasma output positive connected earth, negative connected nozzle of torch, so the volt on nozzle is negative.

The arc voltage is usually higher than 100V during cutting, and it has strong interference during arc start, thus it must be divided with 100:1 or 50:1....before lead into THC.

3.1.1 None isolation voltage divide

As None Isolation Voltage Divide is directly connected with Plasma Power Supply, to enable THC escape from interference caused by the HF during Plasma Arc Start, the Divided Arc Voltage guided into THC is Time-Delayed.

It just needs to prolong the time of lead Arc Voltage into THC, this interference can be avoid effectively. On PTHC-200DC, the delay lead in arc volt into THC is set by Set pierce Button. As showed in figure 3-1.

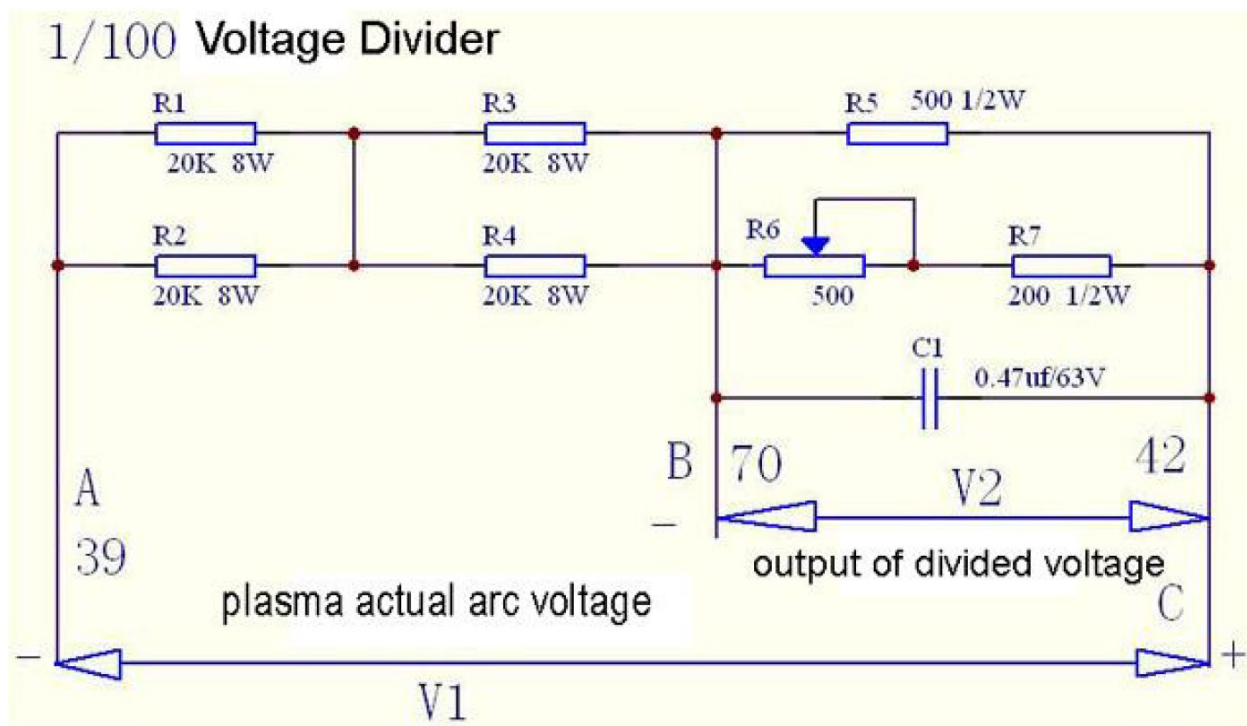

Figure 3-1

Service Support Spirit

3.1.2 Isolation voltage divide

Plasma Arc Voltage is divided by Voltage Divider (offered with PTHC) on 50:1 via none isolate voltage divide, lead into THC after processed by Isolation Circuit. Arc voltage has little effect on THC after Isolation Circuit. Connection as follow:

Voltage divider is usually installed in CNC cabinet or plasma cabinet.

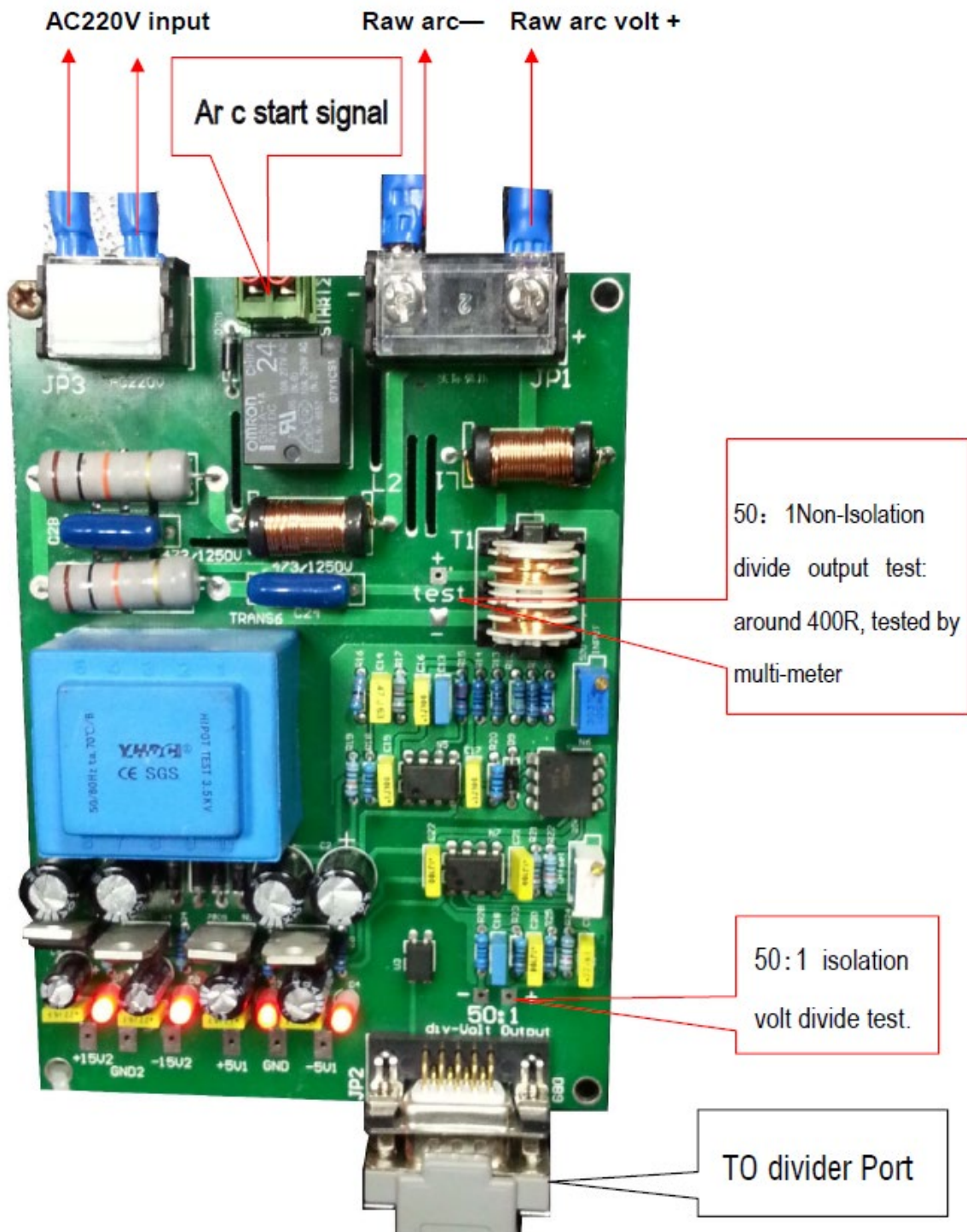

Figure 3-2 Isolation voltage divider wiring guide

Service Support Spirit

Note:

1. If the raw arc volt input mis-connected, Isolation voltage divider has no output. If the divided arc volt into THC mis-connected, THC would display max value.

2. We always suggest Isolation voltage divide, non-isolation volt divide is just a backup. For HF plasma, isolation voltage divide is must, can NOT use non-isolation divide.

3. For China/India OEM plasma, the raw arc volt input should connected to plasma's rectifier output. Because there's very strong HF interference between electrode and work port during Arc start.

3.2 PTHC-IHS controller

3.2.1 PTHC-IHS function

PTHC-IHS controller is specially designed for PHTC-200DC, to improve THC's anti-interference performance. This controller keeps the interference source like plasma arc voltage, arc start signal away from THC control module, and it is isolated connection between IHS controller and PTHC. Meanwhile, It shorten the distance between Torch and IHS controller, effectively avoid plasma's interference to THC and CNC.

3.2.2 PTHC-IHS Interface

PTHC-200DC has proximity switch IHS and Retaining cap IHS as Figure3-3:

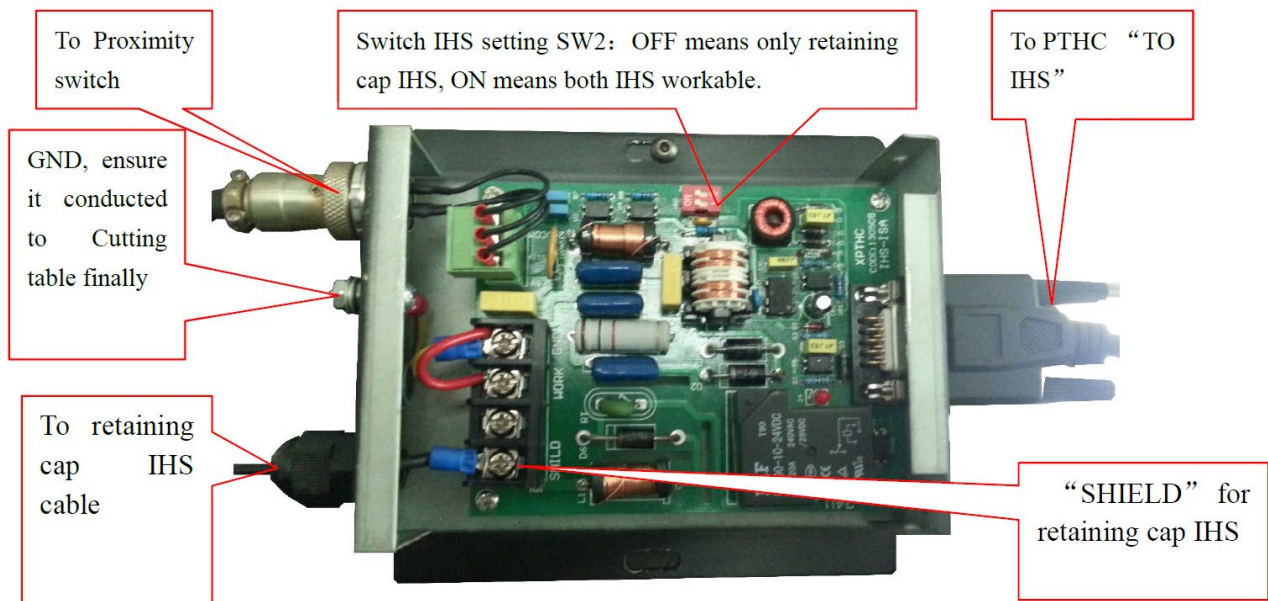

Figure 3-3 PTHC-IHS wiring

Service Support Spirit

SW2 ON means both retaining cap IHS and proximity switch IHS workable, anyone of it can complete IHS process.

If SW2 ON, but proximity switch not connected, torch would keep lifting up, so it should turn SW2 OFF or short the IHS controller's Signal and COM.

Pin(s)	Signal	Description
1	COM	Proximity switch power negative
2	Signal	Proximity switch signal
3	+15V	Proximity switch power positive

We suggest NPN proximity switches connected as follow, any one of them effective, THC can receive this signal.

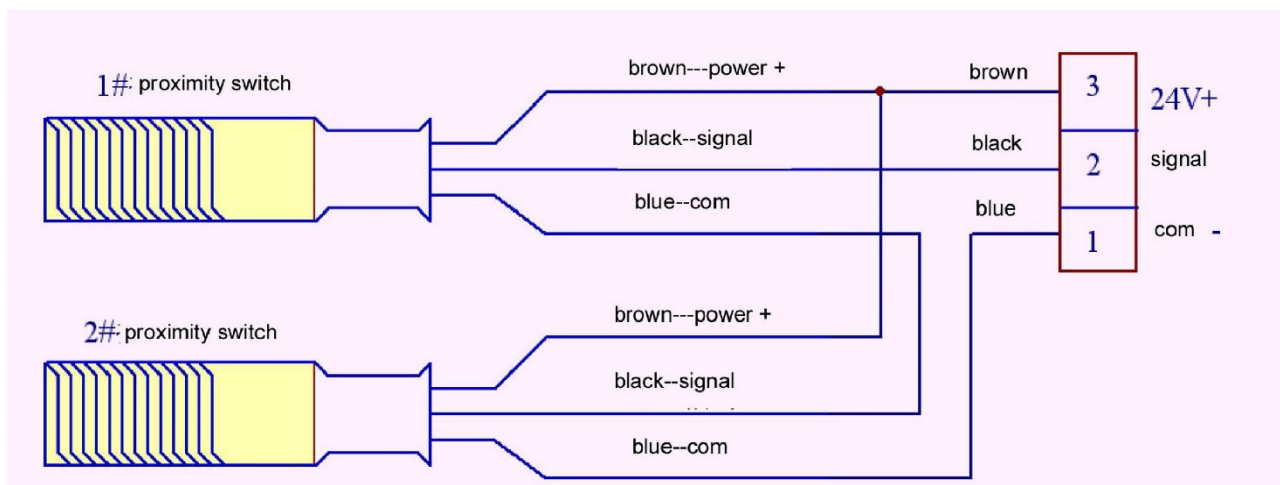

Figure 3-4

Work Process: Once THC received Arc Start signal from CNC, torch moves down, when it reaches workpiece, Proximity Switch leaves proximity position, THC receive. This signal, lifts torch to the set height, (Proximity Switch recovers during lifting). After IHS, THC drives plasma Start Arc.

Service Support Spirit

Proximity Switch IHS is suitable for all plasma IHS.

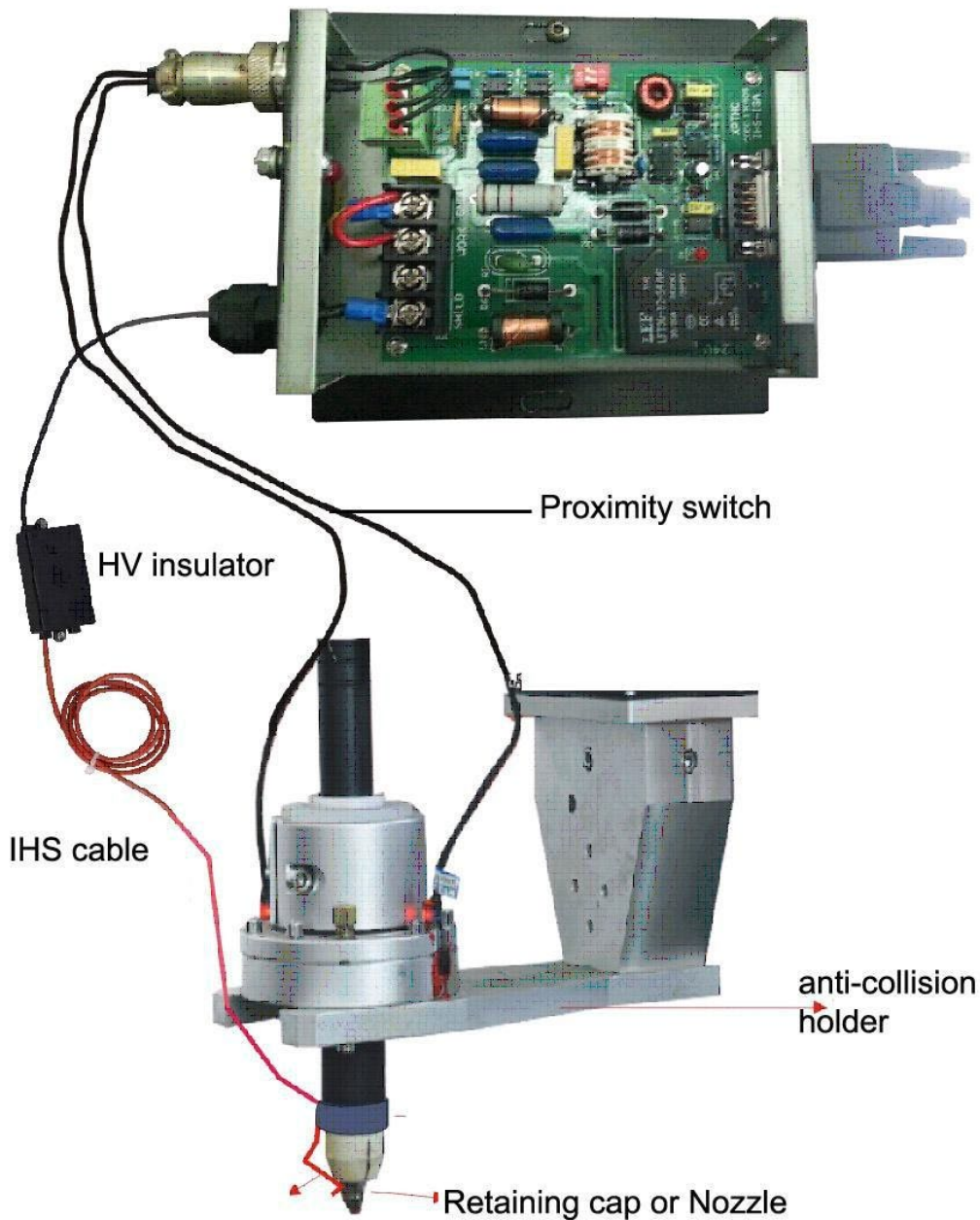

Figure 3-5 PTHC-IHS

Note:

- A, It must use High voltage retaining cap IHS cable if use Ohmic contact IHS.
- B, If only Ohmic contact IHS, SW2 switch must be off.
- C, If use collision output to CNC, proximity switch IHS is must
- D, The GND must be grounded and the cable cross-section $>4\text{mm}^2$.

4. Complete PTHC wiring

